

## Research Article

Petr Čech, Zuzana Paschová, Milan Gaff\*, Haitao Li, and František Kačík

# Synthetic leathers as a possible source of chemicals and odorous substances in indoor environment

<https://doi.org/10.1515/rams-2023-0132>

received November 08, 2022; accepted September 29, 2023

**Abstract:** This article deals with volatile organic substances (VOCs) and odours that can be released into the indoor environment from synthetic leathers that are part of upholstered furniture. The primary task of this study was to provide a detailed analysis of selected synthetic leathers and assess their emission characteristics, including odour substances. VOC emissions were determined using the test chamber method (ČSN EN ISO 16000-9) at a temperature of 23°C and a relative humidity of 50%. The emitted compounds were adsorbed by standard stainless steel tubes with Tenax TA sorbent. VOCs were analysed by thermal desorption and gas chromatography with mass spectrometry. The properties of odours were tested using a Sniffer 9000 device, which was directly connected to a gas chromatograph with a flame ionization detector. The dominant substances (with the highest concentration) that were emitted by samples of tested synthetic leathers include toluene ( $118.2 \mu\text{g}\cdot\text{m}^{-3}$ ), 1,2-propanediol ( $46.2 \mu\text{g}\cdot\text{m}^{-3}$ ), and limonene ( $153.0 \mu\text{g}\cdot\text{m}^{-3}$ ). Ohio synthetic leather produced the most unpleasantness hedonic tone (-4) from all evaluated materials.

**Keywords:** synthetic upholstery leathers, VOCs, odours, indoor air, test chamber, hedonic tone

## 1 Introduction

At present, when a certain comfort is required from the perspective of indoor air quality in interiors, emissions of odorous substances released from furniture, building materials, and interior accessories are becoming a big problem [1]. There are very often problems with unexplained odours in the working environment of offices, public interiors, and residential buildings [2]. Today, both public and private buildings are constructed with a reinforced structure, including an airtight cover, to prevent heat loss due to air infiltration [3], and they are also usually equipped with a mechanical ventilation system. The building materials and building processes used have been modified to meet the highest airtightness requirements. The listed building materials met the requirements of the French Thermal Regulations 2005 (RT 2005) for buildings (air tightness less than  $0.8 \text{ m}^3\cdot\text{h}^{-1}\cdot\text{m}^{-2}$  under 4 Pa and annual conventional primary energy consumption less than  $150 \text{ k}\cdot\text{Wh}\cdot\text{m}^{-2}\cdot\text{year}^{-1}$ ) [4]. The consequences of these changes affect indoor air quality [5].

Volatile organic compounds (VOCs) are particularly interesting among indoor air pollutants due to their levels in indoor air and their adverse effects on human health, and some of them may be toxic [6,7]. There are several internal sources of VOC emissions, including decorative materials (paints, adhesives, wallpapers, carpet, *etc.*), furniture (wood-based panels, leather, plastics, veneered particleboards, *etc.*), and human activities (cooking, smoking, emissions from the human body, *etc.*) [8–12].

VOCs are a large group of various compounds, including natural compounds such as terpenes and alcohols, as well as carbonyl compounds such as ketones, aldehydes, ethers, aromatic hydrocarbons, and acids, which are the main pollutants present in indoor air [13].

\* **Corresponding author: Milan Gaff**, Department of Design and Furniture, Mendel University in Brno, Zemědělská 3, 61300 Brno, Czech Republic; Faculty of Civil Engineering, Experimental Centre, Czech Technical University in Prague, Thakurova 7, 166 29 Prague 6, Czech Republic, e-mail: gaffmilan@gmail.com, milan.gaff@mendelu.cz, tel: +420 778 978 142

**Petr Čech:** Department of Design and Furniture, Mendel University in Brno, Zemědělská 3, 61300 Brno, Czech Republic, e-mail: petr.cech@mendelu.cz

**Zuzana Paschová:** Department of Wood Science and Technology, Mendel University in Brno, Zemědělská 3, 61300 Brno, Czech Republic, e-mail: zuzana.paschova@mendelu.cz

**Haitao Li:** College of Civil Engineering, Nanjing Forestry University, Nanjing, China

**František Kačík:** Department of Chemistry and Chemical Technologies, Technical University in Zvolen, T. G. Masaryka 24, 96001 Zvolen, Slovak Republic

Among internal pollutants, VOCs are of particular concern due to their adverse health effects [14]. Some of them can be odour-active, which depends on the type of chemical substance and its concentration [15]. Particularly, strong odorants can affect the perception of indoor air quality [16]. Unpleasant scents can cause a variety of human side reactions, including annoyance, increased mental stress, headaches, and other health problems [17]. Adverse health effects associated with exposure to VOCs include skin irritation, asthma, cardiovascular disease, and cancer [18].

Odour substances are not necessarily associated with adverse health effects. Unpleasant odours have often been considered a potential risk to human health rather than direct triggers of health effects. Certain chemicals that produce odours are potentially harmful (formaldehyde, styrene, and  $\alpha$ -pinene) [19]. Common sources of indoor smells are heating, ventilation, and air conditioning systems, when there is a transfer of pollutants, including VOCs and odorous substances [20].

Internal sources of odours (carpets, furniture, interior finishes, cigarettes, detergents, insecticides, and human body odours) have their own characteristics and chemical composition [21,22].

Olfactory methods have been widely used to quantify odour intensity. The activity of odorous VOCs can be evaluated using the odour activity value (OAV), which is the ratio of measured concentration values to the odour threshold [23]. The definition of odour threshold is the minimum identifiable odour or recognition threshold [24]. The compound with the largest OAV is considered to be the main odour source.

Interior furnishings such as furniture and wood paneling usually emit formaldehyde [25], which is characterized as sharp and irritating; new carpets release 4-phenylcyclohexene (by-product of a polymerization process in some carpet backing). In addition, some chemicals that are often present in the interior can act in specific ways and produce high-intensity odours. Many VOCs with different odour characteristics can easily evaporate into the air and turn into an odour source (wood-based products). The presence of odours may cause some people to suspect harmful exposure [26]. These chemicals include aromatics (toluene, styrene, and xylene), aldehydes (formaldehyde, acetaldehyde), and terpenes ( $\alpha$ -pinene and limonene). Thus, there is a relationship between the perceived smell and the chemical composition within it [27].

Félix *et al.* described the identification of VOCs from wood-plastic composites (WPCs) performed using gas chromatography with mass spectroscopy (GC-MS) in conjunction with olfactometric analysis. The odour profile was described as sweet and waxy, which was characteristic of WPC. Acetylfuran, acetic acids, and aldehydes were the most identified odorants [28].

Sources of smell in the interior are non-specific, intermittent, and slightly intense. It is therefore very difficult to characterize internal smells and identify their sources. Nevertheless, the characterization of scents (qualitative and quantitative) can help identify sources of pollution, and it plays an important role in the assessment of indoor air quality due to the higher sensitivity of humans to smells [29,30].

In the interior, VOC emissions are examined not only from furniture and upholstered products, but also from other appliances. Ontañón *et al.* [31], for example, dealt with the smell of dishwashers. Liu *et al.* [32] monitored the use of a combination of GC-MS and olfactometry and the reduction of VOC emissions from wood after the removal of the substances causing unpleasant odours by solvent extraction. Another study dealt with the issue of odorous substances in inflatable water toys and devices for teaching swimming, which cause a characteristic odour and are potentially harmful [33].

As the aforementioned overview shows, great attention has been paid to VOC analyses in indoor air. However, a more comprehensive analytical approach is needed for the evaluation of the quality of the indoor environment more objectively. Therefore, the analytical method GC-MS/O was used in this study. This study aimed to identify the key odorant compounds released from four synthetic leathers and find out the effect of time on the change of hedonic tone. The data obtained can be used to create the odour database of synthetic leathers. The following study provides information on possible sources of unpleasant odours in the interior (*e.g.*, upholstered furniture), which reduce indoor air quality and may be the cause of sick building syndrome.

## 2 Materials and methods

This study deals with the issue of the quality of the indoor environment from the perspective of a toxic and odour microclimate. The main purpose of this work is to compare upholstery materials (synthetic leather) in terms of possible load of VOCs. These materials, used in the production of upholstered furniture [34], can be a source of indoor VOC substances and can also emit an unpleasant odour.

The influence of various factors (the type of synthetic leather, material composition, surface treatment of materials, surface weight, *etc.*) on the amount of VOC emissions was studied in this work. In addition, it is possible to hypothesize whether the major and minor component of emissions is influenced by the type of material (type of synthetic leather) and the time factor (time since the beginning of the chamber test).

Based on the qualitative parameters listed in Table 1, the tested materials were selected from the common production process and formatted to the required size (710 × 710 mm). The mentioned upholstery materials are commonly used in public interiors.

In a stainless-steel test chamber (VOC Test 1000, producer: Smykal Ltd.) with a volume of 1 m<sup>3</sup>, a constant temperature of 23.0°C is maintained with an accuracy of ±1.0°C, with the option to change the temperature setting in a range from +15 to +45°C. Relative humidity (RH) is maintained at 50% with an accuracy of ±3% and with the option of setting it in the range of 40–65% RH. The test chamber is equipped with an air exchange (1 m<sup>3</sup>·h<sup>-1</sup>) and air humidification system. Air flow over the surface of the tested object is uniform at a speed of 0.1–0.3 m·s<sup>-1</sup>. The test chamber is gas-tight without overpressure, with the exception of the air inlet and outlet.

The temperature is measured and controlled by a PT 100 sensor in an indirect cooling bath. Humidity is measured and controlled by a capacitive sensor. The evaluated temperature and humidity data are shown on the control system display. Automatic evaluation and control of the amount of air exchange can also be checked on the display of the control unit.

Each synthetic leather sample was carefully wrapped in aluminium foil and transported to a testing laboratory. Prior to the actual measurement, the sample was immediately placed in a test chamber with defined conditions (temperature, humidity, air flow, air exchange in the chamber) pursuant to standard ČSN EN ISO 16000-9 after unpacking.

Subsequently, the VOC emissions emitted by the test sample were collected using sorption tubes with Tenax TA sorbent (porous polymer based on 2,6-diphenyl oxide with a grain size of 0.18–0.25 mm) [35]. The sorption tube with the captured emission sample was analysed by a gas chromatograph

and mass spectrometry with thermal desorption (TD-GC-MS). This methodological principle is shown in Figure 1.

## 2.1 Methodology of qualitative and quantitative determination of VOC emissions

VOC emissions from the tested materials were determined on a qualitative and quantitative level. For selected representatives of VOCs, the exact concentration of the substance in units of µg·m<sup>-3</sup> was determined. The assessment of the total VOC (TVOC) parameter was also an integral part.

The tested materials were monitored depending on the elapsed time since the beginning of the chamber test in time intervals of 1, 3, 7, and 28 days, while the test sample was stored continuously in the chamber for 28 days.

After this time, the sample was removed from the chamber, repacked in aluminium foil, and stored in the test specimen warehouse under laboratory conditions (a temperature of 23°C, a humidity of 50%) until the emission measurement after 120 days.

## 2.2 Sampling

VOC emissions from the tested material stored in the test chamber (a volume of 1 m<sup>3</sup>) were taken using a diaphragm pump (Gilian LFS-113, Sensidyne) and a sorption tube (1/4" diameter 3 and 1/2" length stainless standard tubes with 200 mg of sorbent Tenax TA) in parallel (a sampling rate of 100 mL·min<sup>-1</sup>, a time of 40 min). Breakthrough volumes

**Table 1:** Qualitative parameters of synthetic leather samples

Name of synthetic leather	Material compositions		Producer	Surface weight (g·m <sup>-2</sup> )	Date of starting chamber test
	Foundation material	Surface			
Ohio 210	50% polyester 40% cotton 10% viscose	100% polyurethane	TENA TEX TRADE Ltd.	480	25.02.2020
Tibet 123	81% polyester 15% cotton 4% viscose	100% polyurethane	TENA TEX TRADE Ltd.	450	25.03.2020
Vento 4	100% polyester	100% polyvinyl chloride	TENA TEX TRADE Ltd.	700	25.04.2020
Vinytol 780	50% polyester 50% cotton	100% polyvinyl chloride	SVITAP Ltd.	780	25.05.2020

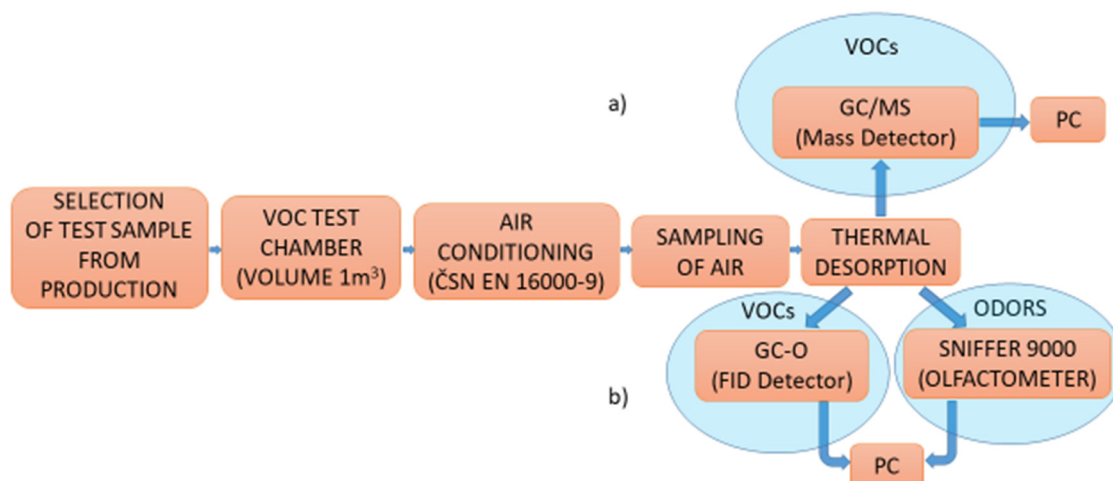

**Figure 1:** Development diagram of individual steps of quantitative determination of VOC emissions (a) and olfactometric assessment (b).

for sorbent Tenax have been tested, and the recommended sampling of air volume (4 L) was intended according to the requirements of the standards (ČSN EN ISO 16017-1, ISO 16000-6). The sample was analysed on a gas chromatograph (HP 6890, Agilent) equipped with a mass selective detector (MSD 5973, Agilent) after thermal desorption at 250°C for 3 min (TD4, Scientific Instrument Services). The device is equipped with an HP-5ms capillary column (column length of 30 m, internal diameter of 0.25 mm, film thickness of 1 µm, Agilent). The identification of compounds (Table 2) was performed using retention times (RTs) and by a comparison with the spectra of the GC-MS data library (NIST 05).

The TVOC parameter was determined as the sum of the concentration of the identified and unidentified VOCs eluting between and including *n*-hexane and *n*-hexadecane on a gas chromatographic column (5% phenyl/95% methyl polysiloxane phase) [36]. All peaks in the retention interval of *n*-hexane and *n*-hexadecane are integrated in the total ionic current chromatogram. The peak area of the deuterated *o*-xylene – internal standard (D10-X) is subtracted from the sum of the areas of all peaks. This one was added to the sample to check the yield of the method. The resulting TVOC was then quantified after conversion to a toluene calibration curve.

### 2.3 Olfactometric assessment method with the Sniffer 9000 device

Sniffer 9000 (Brechtbühler AG) was directly connected to a gas chromatograph (HP 4890, Agilent) with a flame ionization detector (FID). Samples of the VOC mixture were

separated into individual compounds in a capillary column (HP-5ms). The stream of separated components is divided into two parts. One exit continues to the FID detector and the other to the Sniffer 9000, evenly in a 1:1 ratio to both systems. The part of the substances that continues to be assessed for the assessor's olfactory system is still heated and moistened with demineralized water. These measures serve for maximum separation and olfactometric resolution of the assessed substances as well as the olfactory comfort of the assessor. The below methodical procedure is shown in Figure 2b.

### 2.4 Determining the hedonic tone of individual VOCs contained in the mixture

The hedonic tone (sensory assessment of olfactory perception from the perspective of pleasant/unpleasant smell) for individual substances is determined using Sniffer 9000. By combining a gas chromatograph and Sniffer 9000, it is possible to divide the individual substances contained in the mixture of the assessed air and dose them for evaluation separately depending on the RT of the assessed compound. Selected assessors determine the hedonic tone of individual substances according to the scale of description of hedonic load using a recording device that is part of it. At the same time, time data (RT) with the nature of smell and pleasantness, expressed by the sign+/ or unpleasantness expressed by the sign-/ , are recorded in the prepared tables. The output is a so-called olfactogram (graph of perceptions with RTs). By overlaying it with the chromatogram, we assign the identified substance to the individual records.

Table 2: VOC emissions from synthetic leather Ohio 210

VOCs	RT [min]	Time dependence [days]				
		1	3	7	28	120
Average of result $\pm$ expanded measurement uncertainty [ $\mu\text{g}\cdot\text{m}^{-3}$ ]						
Butanal	2.926	4.5 $\pm$ 1.4	3.3 $\pm$ 1.0	2.7 $\pm$ 0.8	2.1 $\pm$ 0.6	1.5 $\pm$ 0.5
Ethyl acetate	3.838	6.9 $\pm$ 2.1	5.1 $\pm$ 1.5	4.2 $\pm$ 1.3	3.6 $\pm$ 1.1	2.4 $\pm$ 0.7
Crotonaldehyde	5.210	3.0 $\pm$ 0.9	2.4 $\pm$ 0.7	1.8 $\pm$ 0.5	1.5 $\pm$ 0.5	1.2 $\pm$ 0.4
Benzene	5.622	8.7 $\pm$ 2.6	6.6 $\pm$ 2.0	5.4 $\pm$ 1.6	4.5 $\pm$ 1.4	3.0 $\pm$ 0.9
1-Methoxy-2-propanol	6.094	6.3 $\pm$ 1.9	4.8 $\pm$ 1.4	3.9 $\pm$ 1.2	3.3 $\pm$ 1.0	2.1 $\pm$ 0.6
Pentanal	6.808	13.8 $\pm$ 4.1	10.5 $\pm$ 3.2	8.7 $\pm$ 2.6	6.9 $\pm$ 2.1	4.8 $\pm$ 1.4
Trichloroethylene	6.955	0.6 $\pm$ 0.2	0.6 $\pm$ 0.2	0.3 $\pm$ 0.09	0.3 $\pm$ 0.09	0.3 $\pm$ 0.09
Toluene	9.356	88.8 $\pm$ 26.6	67.5 $\pm$ 20.3	55.2 $\pm$ 16.5	45.3 $\pm$ 13.6	30.6 $\pm$ 9.2
Hexanal	10.153	23.1 $\pm$ 6.9	17.7 $\pm$ 5.3	14.4 $\pm$ 4.3	11.7 $\pm$ 3.5	8.1 $\pm$ 2.4
Tetrachloroethylene	10.562	0.6 $\pm$ 0.2	0.6 $\pm$ 0.2	0.3 $\pm$ 0.1	0.3 $\pm$ 0.1	0.3 $\pm$ 0.1
<i>n</i> -Butyl acetate	10.588	9.3 $\pm$ 2.8	7.2 $\pm$ 2.2	5.7 $\pm$ 1.7	4.8 $\pm$ 1.4	3.3 $\pm$ 1.0
Furfural	11.169	1.8 $\pm$ 0.5	1.5 $\pm$ 0.5	1.2 $\pm$ 0.4	0.9 $\pm$ 0.3	0.6 $\pm$ 0.2
Ethylbenzene	12.048	8.1 $\pm$ 2.4	6.3 $\pm$ 1.9	5.1 $\pm$ 1.5	4.2 $\pm$ 1.3	2.7 $\pm$ 0.8
1,2-Propanediol	12.229	46.2 $\pm$ 13.9	35.1 $\pm$ 10.5	27.6 $\pm$ 8.3	23.7 $\pm$ 7.1	15.9 $\pm$ 4.8
<i>m,p</i> -Xylene	12.478	27.0 $\pm$ 8.1	20.4 $\pm$ 6.1	16.8 $\pm$ 5.0	13.8 $\pm$ 4.1	9.3 $\pm$ 2.8
Styrene	12.833	2.4 $\pm$ 0.7	1.8 $\pm$ 0.5	1.5 $\pm$ 0.5	1.2 $\pm$ 0.4	0.9 $\pm$ 0.3
Cyclohexanone	12.897	2.7 $\pm$ 0.8	2.1 $\pm$ 0.6	1.8 $\pm$ 0.5	1.2 $\pm$ 0.4	0.6 $\pm$ 0.2
<i>o</i> -Xylene	12.909	9.9 $\pm$ 3.0	7.5 $\pm$ 2.3	6.3 $\pm$ 1.9	5.1 $\pm$ 1.5	3.6 $\pm$ 1.1
Heptanal	12.996	0.6 $\pm$ 0.2	0.6 $\pm$ 0.2	0.3 $\pm$ 0.09	0.3 $\pm$ 0.09	0.3 $\pm$ 0.09
2-Butoxyethanol	13.088	1.8 $\pm$ 0.5	1.5 $\pm$ 0.5	1.2 $\pm$ 0.4	0.9 $\pm$ 0.3	0.6 $\pm$ 0.2
$\alpha$ -Pinene	13.987	12.6 $\pm$ 3.8	9.6 $\pm$ 2.9	7.8 $\pm$ 2.3	6.3 $\pm$ 1.9	4.2 $\pm$ 1.3
Camphene	14.403	1.8 $\pm$ 0.5	1.5 $\pm$ 0.5	1.2 $\pm$ 0.4	0.9 $\pm$ 0.3	0.6 $\pm$ 0.2
Benzaldehyde	14.576	4.5 $\pm$ 1.4	3.3 $\pm$ 1.0	2.7 $\pm$ 0.8	2.1 $\pm$ 0.6	1.5 $\pm$ 0.5
3-Ethyltoluene	14.595	3.9 $\pm$ 1.2	3.0 $\pm$ 0.9	2.4 $\pm$ 0.7	1.8 $\pm$ 0.5	1.2 $\pm$ 0.4
4-Ethyltoluene	14.638	1.2 $\pm$ 0.4	0.9 $\pm$ 0.3	0.9 $\pm$ 0.3	0.6 $\pm$ 0.2	0.3 $\pm$ 0.1
1,3,5-Trimethylbenzene	14.755	3.9 $\pm$ 1.2	3.0 $\pm$ 0.9	2.4 $\pm$ 0.7	1.8 $\pm$ 0.5	1.2 $\pm$ 0.4
Phenol	14.872	2.4 $\pm$ 0.7	1.8 $\pm$ 0.5	1.5 $\pm$ 0.5	1.2 $\pm$ 0.4	0.9 $\pm$ 0.3
$\beta$ -Pinene	15.079	3.0 $\pm$ 0.9	2.4 $\pm$ 0.7	1.8 $\pm$ 0.5	1.5 $\pm$ 0.5	1.2 $\pm$ 0.4
2-Ethyltoluene	15.093	2.4 $\pm$ 0.7	1.8 $\pm$ 0.5	1.5 $\pm$ 0.5	1.2 $\pm$ 0.4	0.9 $\pm$ 0.3
Myrcene	15.145	0.6 $\pm$ 0.2	0.6 $\pm$ 0.2	0.3 $\pm$ 0.09	0.3 $\pm$ 0.09	0.1 $\pm$ 0.03
1,2,4-Trimethylbenzene	15.377	3.0 $\pm$ 0.9	2.4 $\pm$ 0.7	1.8 $\pm$ 0.5	1.5 $\pm$ 0.5	1.2 $\pm$ 0.4
Octanal	15.388	8.1 $\pm$ 2.4	6.3 $\pm$ 1.9	5.1 $\pm$ 1.5	4.2 $\pm$ 1.3	2.7 $\pm$ 0.8
$\alpha$ -Phellandrene	15.647	1.2 $\pm$ 0.4	0.9 $\pm$ 0.3	0.9 $\pm$ 0.3	0.6 $\pm$ 0.2	0.3 $\pm$ 0.1
3- $\delta$ -Carene	15.793	5.7 $\pm$ 1.7	4.2 $\pm$ 1.3	3.6 $\pm$ 1.1	3.0 $\pm$ 0.9	1.8 $\pm$ 0.5
1,4-Dichlorobenzene	15.863	0.6 $\pm$ 0.2	0.6 $\pm$ 0.2	0.3 $\pm$ 0.09	0.3 $\pm$ 0.09	0.3 $\pm$ 0.09
1,2,3-Trimethylbenzene	16.083	1.8 $\pm$ 0.5	1.5 $\pm$ 0.5	1.2 $\pm$ 0.4	0.9 $\pm$ 0.3	0.6 $\pm$ 0.2
Limonene	16.175	153.0 $\pm$ 45.9	116.7 $\pm$ 35.0	95.4 $\pm$ 28.6	78.3 $\pm$ 23.5	52.8 $\pm$ 15.8
$\gamma$ -Terpinene	16.796	0.6 $\pm$ 0.2	0.6 $\pm$ 0.2	0.3 $\pm$ 0.09	0.3 $\pm$ 0.09	0.3 $\pm$ 0.09
Nonanal	17.577	4.5 $\pm$ 1.4	3.3 $\pm$ 1.0	2.7 $\pm$ 0.8	2.1 $\pm$ 0.6	1.5 $\pm$ 0.5
Decanal	19.594	7.5 $\pm$ 2.3	5.7 $\pm$ 1.7	4.8 $\pm$ 1.4	3.9 $\pm$ 1.2	2.7 $\pm$ 0.8
Bornyl acetate	21.360	0.6 $\pm$ 0.2	0.6 $\pm$ 0.2	0.3 $\pm$ 0.09	0.3 $\pm$ 0.09	0.1 $\pm$ 0.03
TVOC <sub>MS</sub>		1,644 $\pm$ 493	1,251 $\pm$ 375	1,026 $\pm$ 308	840 $\pm$ 252	567 $\pm$ 170

## 2.5 Statistical analysis

For evaluating the results, analysis of variance (ANOVA) was used. Based on the P-level value and Fisher's F tests, it was determined whether a factor affected the values of the monitored characteristics. Diagrams were constructed for the 95% confidence interval, reflecting the significance level of 0.05 ( $P < 0.05$ ), and the results were verified with Duncan's tests.

## 3 Results and discussion

The present study focused on the issue of VOC emissions from synthetic leathers used to produce furniture or interior accessories. Emissions of VOCs from different types of synthetic upholstery leathers, depending on the factors monitored, were assessed with a GC-MS analysis. VOC emissions from test samples were measured as a function of time [37–40].

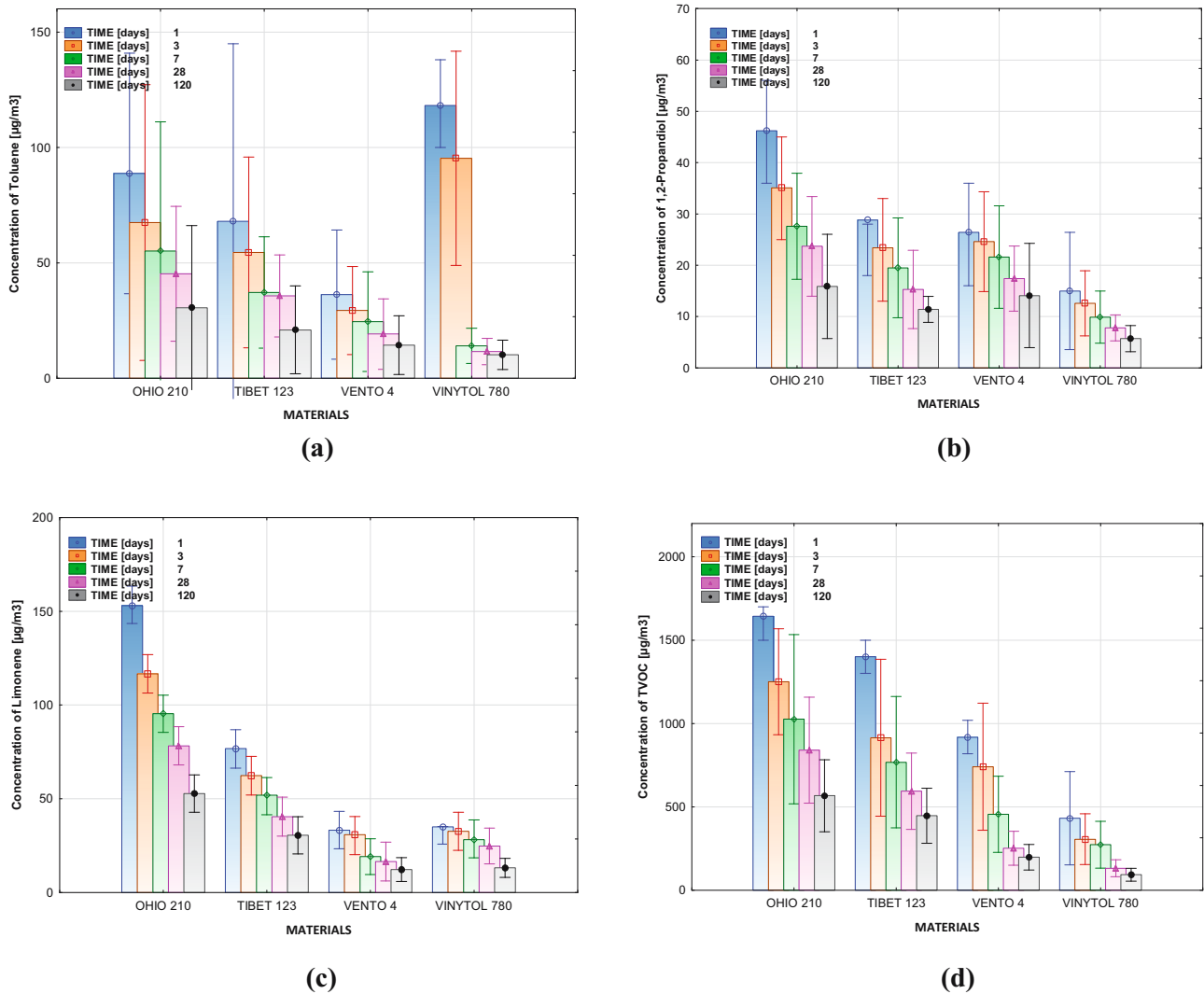

**Figure 2:** Comparison of concentration values of selected substances and the TVOC parameter emitted from tested materials: (a) toluene, (b) 1,2-propanediol, (c) limonene, and (d) TVOC parameter.

The experimental part of this research task assessed the tested materials from several points of view:

- determination of the impact of the material composition (foundation/surface) of synthetic leather on the amount of VOC emissions,
- determination of the impact of the surface weight of synthetic leather ( $\text{g}\cdot\text{m}^{-2}$ ) on the amount of VOC emissions,
- olfactometric assessment of synthetic leathers based on the determination of the hedonic tone of the odour.

Based on relevant literature sources [41–45], individual VOCs that can be released from upholstery materials used in upholstered furniture have been selected.

Figure 4(a–d) shows the values for the three dominant volatiles that occurred in all samples – toluene, 1,2-

propanediol, and limonene (Figure 4a–c), and for the sum of TVOC (Figure 4d).

The model data of VOC emissions from synthetic leather sample (Ohio 210) are shown in Table 2. The given table gives the average concentration values (from two parallel determinations) of the individual monitored VOC representatives from the sample that emitted the most emissions.

The concentration values of selected substances were measured depending on the time since the beginning of the chamber test (1, 3, 7, 28, and 120 days).

The results of the multifactor ANOVA evaluating the effect of individual monitored factors: material (synthetic leathers) and time (1, 3, 7, 28, and 120 days from the start of the chamber test), as well as their interaction on the concentrations of the dominant monitored substances (toluene, 1,2-

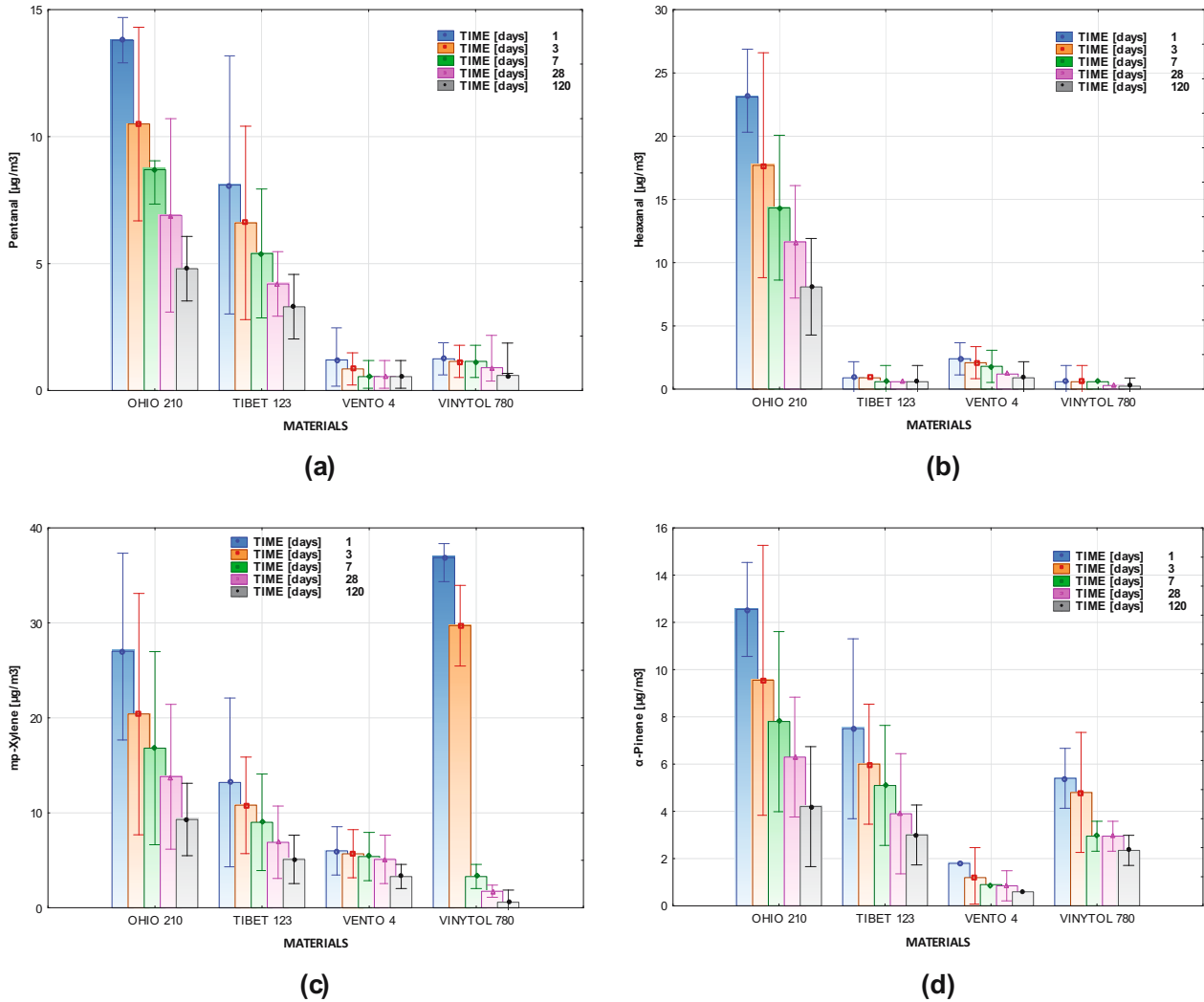

**Figure 3:** Majority composition of chemical substances from tested materials: (a) pentanal, (b) hexanal, (c) *m,p*-xylene, and (d)  $\alpha$ -pinene.

propanediol, limonene, and TVOC), can be considered statistically very significant in all observed cases based on the level of significance  $P$  and Fisher's  $F$  test (Figure 2a–d).

The highest concentration of selected majority compounds (except toluene) was found in Ohio synthetic leather when measured after day 1. Figure 2a–d shows the decrease in concentrations of monitored substances since the beginning of the chamber test. A similar trend can be seen for the TVOC.

Table 2 shows that more than 40 individual VOCs released from synthetic leather samples were assessed, including several types of aromatic substances, aldehydes, terpenes, and typical chemicals from natural and synthetic leathers, such as propylene glycol-1-methyl ether (synonym: 1-methoxy-2-propanol, CAS No. 107-98-2), propylene glycol (synonym: 1,2-propanediol, CAS No. 57-55-6).

The measured data show that the substances with the highest concentrations were limonene or toluene. However,

one of the major compounds found in our VOC collection of tested coating materials was 1,2-propanediol. It is used in the surface treatment process, and it acts as a coalescing substance in the application of coatings [46]. Synthetic leather also emitted minor amounts of 1-methoxy-2-propanol. This compound is widely used in primers, high-viscosity spray paints, and binders in formulated topcoats as constitutive additives, and it is mainly used in final leather surface finishes [47–50].

### 3.1 Majority and minority composition of chemical substances in upholstery materials

Emission volatility can be divided into several groups depending on their emitted quantity. The first group of major volatile compounds consists of those with a high content of the substance in the sample. These are concentrations of tens

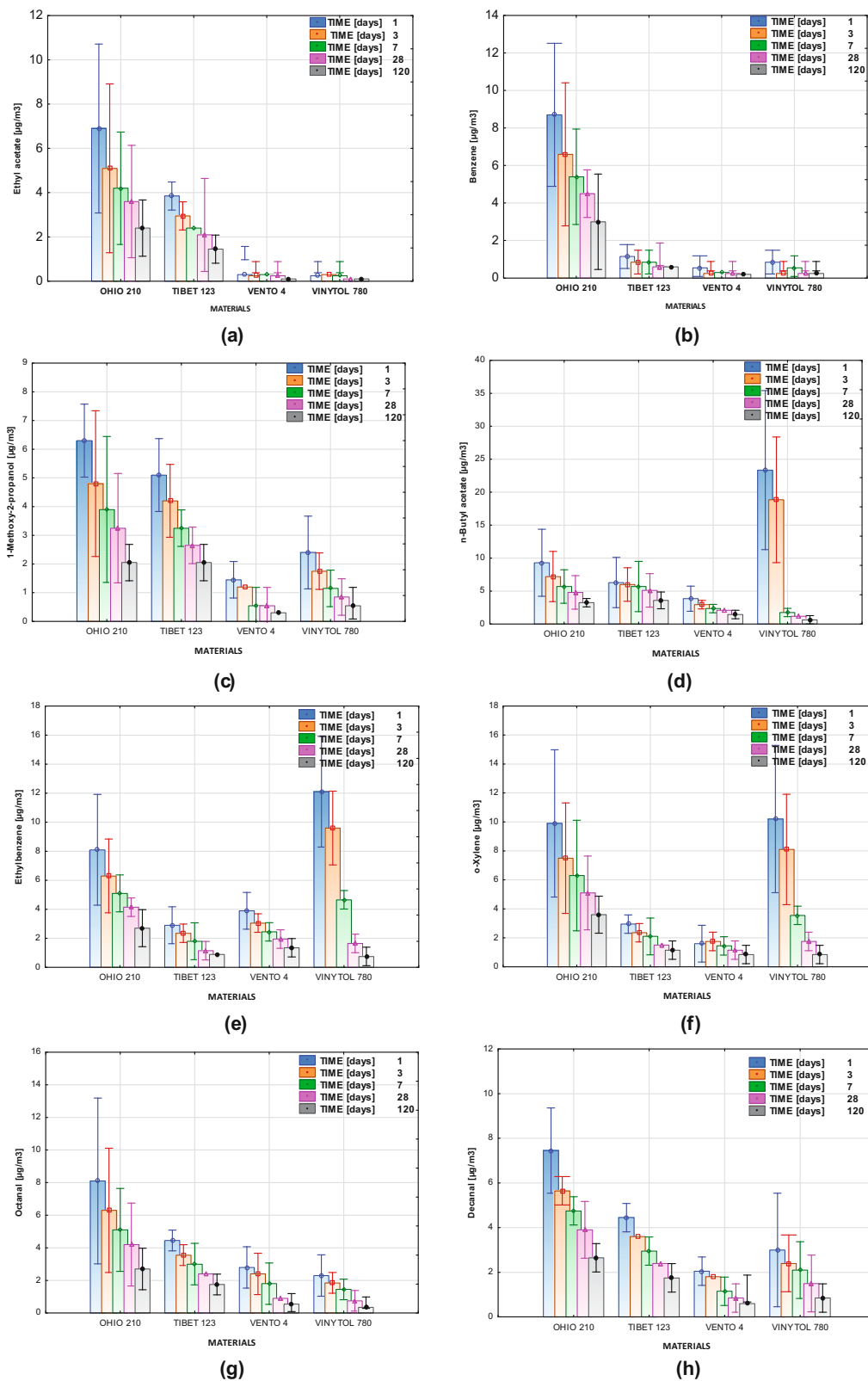

**Figure 4:** Minority composition of chemical substances from tested materials. (a) ethyl acetate, (b) benzene, (c) 1-methoxy-2-propanol, (d) *n*-butyl acetate, (e) ethylbenzene, (f) *o*-xylene, (g) octanal, and (h) decanal.



or over a hundred of  $\mu\text{g}\cdot\text{m}^{-3}$ . The second group consists of minority substances, in concentrations of units, eventual tens of  $\mu\text{g}\cdot\text{m}^{-3}$ . The last group consists of trace elements with a concentration of  $<10 \mu\text{g}\cdot\text{m}^{-3}$ . This concentration represents five times the maximum concentration of an individual substance (limit value) in the background values of the test chamber [51] (ČSN EN ISO 16000-9, 2007). Figures 3 and 4 show the major and minor compounds.

Based on the performed statistical analysis (multi-factor ANOVA) and the determined level of significance  $P$  and Fisher's  $F$  test, it can be stated that the monitored factors (type of material and time) and their interaction, affecting the monitored parameter – the majority share of VOC emissions (concentration of pentanal, hexanal,  $m,p$ -xylene, and  $\alpha$ -pinene) – from the evaluated synthetic leather samples, are statistically highly significant (Figure 3a–d).

Figure 3 presents the data of species composition of VOCs from synthetic leathers. The monitored substances such as pentanal, hexanal,  $m,p$ -xylene, and  $\alpha$ -pinene have a significant share in the minority composition of VOC emissions. The concentration of these chemicals was found in tens  $\mu\text{g}\cdot\text{m}^{-3}$ .

A statistical evaluation of the measured data (concentration of monitored VOCs) demonstrated the effect of monitored factors (type of material and time) on the assessed parameter (concentration of ethyl acetate, benzene, 1-methoxy-2-propanol,  $n$ -butyl acetate, ethylbenzene,  $o$ -xylene, octanal, and decanal), *i.e.*, the minority share of emissions in the total amount of monitored analytes in the tested samples (synthetic leather). This hypothesis is confirmed by the level of significance  $P$  and Fisher's  $F$  test in the performed multi-factor ANOVA (Figure 4a–h).

Figure 4 assesses the minor components of VOCs from tested synthetic leathers as a function of time since the start of the chamber test. These substances (eight compounds) account for a minority interest in total emissions.

The measured data show a minimal effect of different tested materials on BTEX concentrations (benzene, toluene, ethylbenzene,  $m,p$ -xylene,  $o$ -xylene), except for toluene. These compounds are often determined as a separate group in different environmental matrices for their toxic effect on human health [52–55].

A further group of monitored substances, such as terpenes, showed a similar trend as the BTEX group (apart from limonene). The concentration of these VOCs was very different (from  $0.6 \mu\text{g}\cdot\text{m}^{-3}$  for the monitored terpenes to almost  $23.1 \mu\text{g}\cdot\text{m}^{-3}$  for aldehydes, especially for hexanal), and they have a declining trend over time [45]. Today, the health effects of aldehydes such as  $n$ -hexanal on the human body are well known. Evaporation and the simultaneous action of this substance do not cause a specific disease, but

it can cause health problems such as irritation of the eye and nasal mucosa, headaches, and fatigue [56].

### 3.2 Determining the impact of the material composition of synthetic leather (foundation material and type of surface treatment) on the amount of VOC emissions

The VOC emission from each sample is undoubtedly affected by its material composition or the type of surface treatment. In tested synthetic leather samples, these were products made of polyester, cotton, and viscose in various proportions of material content (Table 1), from Vento synthetic leather, which was made of 100% polyester, through Vinytol with a material composition of 50% polyester and 50% cotton, to Ohio and Tibet leather made from a combination of polyester, cotton, and viscose in significantly different material composition ratios.

The aforementioned compounds, such as hexanal, ethylbenzene, and decanal, were also found in another study. Richter *et al.* [57] dealt with the issue of the release of odorous substances from textiles. The study shows that polyester-based textile fibres release much more VOCs than fabrics made from cotton or viscose. However, this hypothesis has not been confirmed in our study.

Figure 5 shows the dependence of TVOC emission on the polyester content in synthetic leather. The trend shows that the more polyester synthetic leather contains, the lower the TVOC emissions.

There is also a connection between the types of surface treatment. Synthetic leathers Ohio and Tibet, which achieved significantly higher TVOC emissions ( $1,644$  and  $1,401 \mu\text{g}\cdot\text{m}^{-3}$ ),

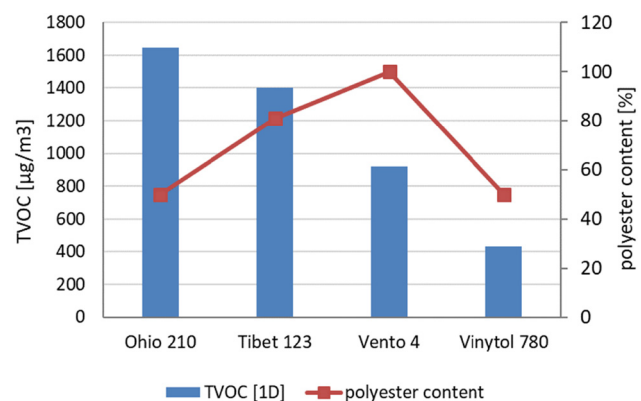
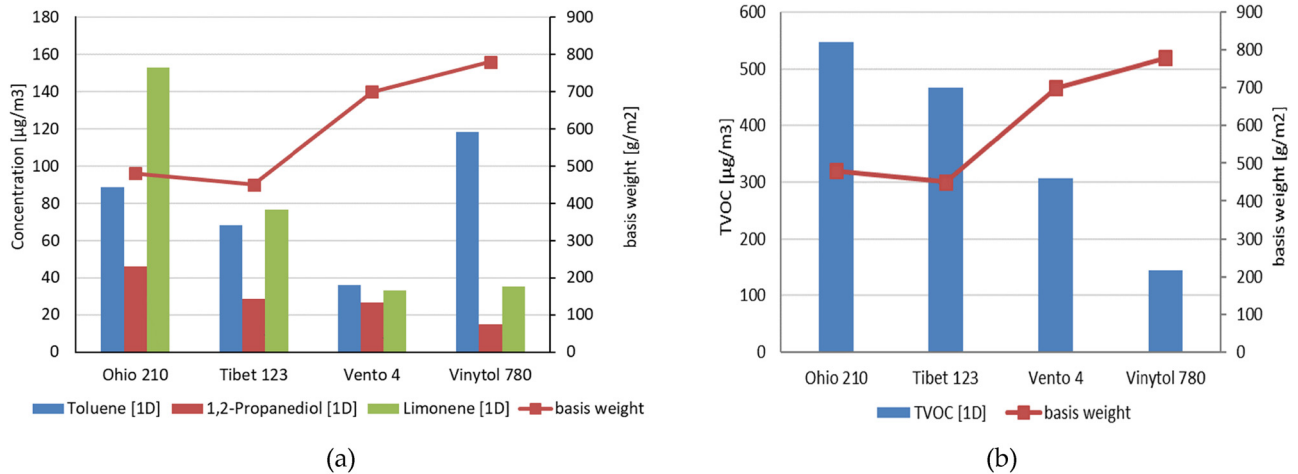

Figure 5: Dependence of TVOC emission on polyester content in the sample.



**Figure 6:** Effect of the base weight of synthetic leather on concentrations of selected substances and the TVOC parameter (1 day): (a) toluene, 1,2-propanediol, limonene and (b) TVOC parameter.

were surface treated with polyurethane varnish. In contrast, synthetic Vento and Vinytol leathers with overall lower TVOC emissions ( $918$  and  $432 \mu\text{g}\cdot\text{m}^{-3}$ ) were treated with polyvinyl chloride.

### 3.3 Determining the impact of the surface weight of synthetic leather on the amount of VOC emissions

In the next part of the experiment, the dependence of VOC emission on the base weight of the material was monitored. The results show that the higher the surface weight of the material, the lower the VOC and TVOC emissions (Figure 6). The only exception where this dependence does not apply is the concentration of toluene in the leather marked as Vinytol. Here, we suppose that the deviation may have been caused by a different manufacturer of synthetic leather than the other samples (Table 1).

In terms of material composition, the largest amount of VOCs was emitted by a sample of Ohio synthetic leather;

its base is composed of a mixture of synthetic materials and its surface is treated with a layer of polyurethane. In contrast, very low concentrations of VOCs were released from the Vinytol test sample, which was made from a mixture of polyester and cotton fibres, with a layer of polyvinyl chloride surface treatment [58].

Figure 6(a) shows the impact of the base weight of synthetic leather on the amount of VOC emissions. These graphs show the dependence of the base weight of the tested material on concentration of the selected chemical substance (toluene, 1,2-propanediol, and limonene). High concentrations of the monitored substances were found in synthetic leather Ohio, and the highest concentration was measured in the substance limonene simultaneously (over  $150 \mu\text{g}\cdot\text{m}^{-3}$ ). The highest amount of total emissions (Figure 6b) was found for the same synthetic leather ( $1,644 \mu\text{g}\cdot\text{m}^{-3}$ ).

Measured concentrations of VOC substances also show that synthetic coating materials (layered textiles) with a lower surface weight (around  $500 \text{g}\cdot\text{m}^{-2}$ ) show higher VOC concentrations compared to materials with a higher surface weight (in the range of  $700\text{--}800 \text{g}\cdot\text{m}^{-2}$ ). The observed TVOC

Hedonic Tone								
-4	-3	-2	-1	0	1	2	3	4
extremely unpleasant	moderate unpleasant	unpleasant	slightly unpleasant	neutral	slightly pleasant	pleasant	moderate pleasant	extremely pleasant

**Figure 7:** Hedonic tone – odour rating scale.

**Table 3:** Values of hedonic tone from synthetic leather – Ohio 210 and Tibet 123

VOCs	RT	Hedonic tone according to standard ČSN EN 13725 time dependence [days]									
		Synthetic leather Ohio 210					Synthetic leather Tibet 123				
		1	3	7	28	120	1	3	7	28	120
1-Methoxy-2-propanol	8.194	-2	-2	-2	-1	-1	-2	-1	-1	-1	N.D.
3-Heptanone	17.441	-4	-3	-3	-2	-1	-3	-3	-2	-1	N.D.
2-Methyl-2,4-pentanediol	18.867	-3	-3	-2	-1	N.D.*	-2	-2	-2	-1	N.D.
Benzaldehyde	19.835	-4	-4	-3	-3	-1	-3	-3	-2	-2	-1
2-(2-Ethoxy-ethanol)	21.294	-2	-2	-1	-1	N.D.	-2	-1	-1	-1	N.D.
Benzyl alcohol	22.876	-4	-4	-4	-3	-2	-3	-3	-3	-2	-1
2-Butoxyethyl acetate	23.527	-4	-4	-4	-2	-1	-3	-3	-2	-2	N.D.
Diisoamylene	24.628	-3	-3	-2	-1	N.D.	-2	-2	-1	N.D.	N.D.

\*N.D. [not detected].

values decrease depending on the time since the beginning of the chamber test (Figure 2d) [59].

### 3.4 Olfactometric assessment of synthetic leathers based on the hedonic tone of the odour

The subject of this part of the work was olfactometric assessment of synthetic covering materials. The main task was to determine the hedonic tone (Figure 7) of the substances captured by the olfactory system (human nose). Hedonic tone defines the pleasantness and unpleasantness of an odour. The hedonic odour tone of the perceived concentration was evaluated according to a category scale ranging from -4 (extremely unpleasant) through zero (neither pleasant nor unpleasant) to +4 (extremely pleasant) [60].

The selected assessors met the professional requirements according to the [61] ČSN EN 13725 standard. The

recorded substances and hedonic tone values are shown in Tables 3 and 4. It is clear from the tables that the substances listed here were different from the compounds quantified (Table 2). This can be explained by the fact that substances that have a small peak area (below the limit of quantification) can also be olfactometrically interesting, in terms of the negative hedonic tone (e.g., benzaldehyde, benzyl alcohol).

Tables 3 and 4 show the sensory hedonic ratings of individual VOCs contained in the mixture. These tables present the values of hedonic tone of tested samples depending on the material composition and surface finish. The tables show the dependence of the time from the beginning of the chamber test on the values of the (negative) hedonic tone. Compounds that produced the unpleasant odour include benzaldehyde, benzyl alcohol, 3-heptanone, or 2-butoxyethyl acetate.

Figure 8 shows a graphical representation of the sum values of the negative hedonic tone that the individual

**Table 4:** Values of hedonic tone from synthetic leather – Vento 4 and Vinytol 780

VOCs	RT	Hedonic tone according to standard ČSN EN 13725 Time dependence [days]									
		Synthetic leather Vento 4					Synthetic leather Vinytol 780				
		1	3	7	28	120	1	3	7	28	120
1-Methoxy-2-propanol	8.194	-1	-1	-1	N.D.	N.D.	-2	-1	-1	N.D.	N.D.
3-Heptanone	17.441	-3	-2	-1	-1	N.D.	-2	-2	-1	-1	N.D.
2-Methyl-2,4-pentanediol	18.867	-1	-1	-1	N.D.	N.D.	-1	-1	N.D.	N.D.	N.D.
Benzaldehyde	19.835	-2	-2	-1	-1	N.D.	-2	-1	-1	-1	N.D.
2-(2-Ethoxy-ethanol)	21.294	-1	-1	-1	N.D.	N.D.	-1	-1	-1	N.D.	N.D.
Benzyl alcohol	22.876	-2	-2	-1	-1	N.D.	-2	-1	-1	-1	N.D.
2-Butoxyethyl acetate	23.527	-2	-2	-2	-1	N.D.	-1	-2	-1	-1	N.D.
Diisoamylene	24.628	-2	-1	-1	N.D.	N.D.	-1	-1	-1	-1	N.D.

\*N.D. [not detected].

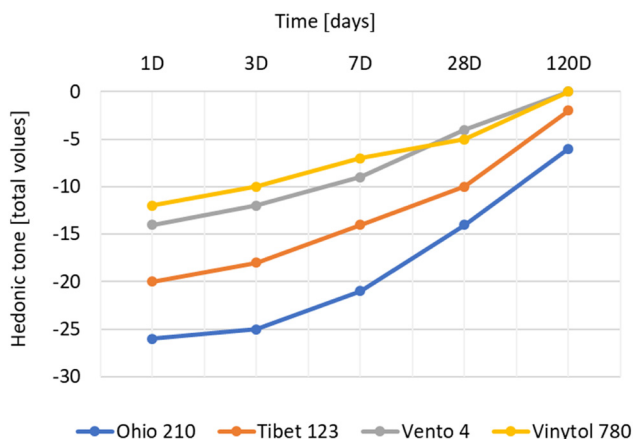

**Figure 8:** Total value of the negative hedonic tone.

samples showed. This value indicates the sum of hedonic tone values [27] as a function of time since the beginning of the chamber test. All tested materials emitted (more or less) an unpleasant odour. The values clearly show that the most negative hedonic tone was emitted by the Ohio leather in all time periods of the measurement.

It has also been proven that the intensity of the odour is related, as in the case of emissions of volatile substances (see Chapters 3.2 and 3.3), to its surface treatment and to its base weight. Synthetic leathers Ohio and Tibet, which produced a more intense odour, belong to the group of samples whose surface was treated with polyurethane varnish and whose surface weight was lower (approximately  $500 \text{ g}\cdot\text{m}^{-2}$ ). Vento and Vinytol leathers with a lower hedonic tone intensity were treated with a varnish based on polyvinyl chloride, and their surface weight was higher (approx.  $700\text{--}800 \text{ g}\cdot\text{m}^{-2}$ ). Unlike VOC and TVOC emissions, the dependence of the odour intensity on the material composition has not been proven here.

## 4 Conclusions

This article assesses the issue of VOC emissions from synthetic upholstery materials used in the production of upholstered furniture and interior accessories.

The test chamber results showed that the concentrations of VOCs from the respective tested materials are influenced by the type of synthetic leather as well as the different material composition of the carrier textile (polyester content) and the type of polymer (polyvinyl chloride/polyurethane) used for synthetic leather finishing.

The results of this study showed that the highest concentration was found in substances such as limonene

(terpene), toluene (aromatic substance), and 1,2-propanediol (alcohol-diol). The Ohio sample tested emitted the highest concentrations of limonene ( $153.0 \mu\text{g}\cdot\text{m}^{-3}$ ) and 1,2-propanediol ( $15.4 \mu\text{g}\cdot\text{m}^{-3}$ ), while the Vinytol sample showed high concentrations of toluene ( $118.2 \mu\text{g}\cdot\text{m}^{-3}$ ). The measured data revealed low concentrations of chemicals such as hexanal, 1-methoxy-2-propanol, or BTEX group.

The measured values of the TVOC parameter ranged from  $432 \mu\text{g}\cdot\text{m}^{-3}$  (from the Vinytol synthetic leather sample) to  $1,644 \mu\text{g}\cdot\text{m}^{-3}$  in the Ohio sample.

Ohio synthetic leather, whose material composition consists of a mixture of synthetic materials with a polyurethane varnish surface treatment, showed the highest amount of VOC emissions.

By measuring the VOC concentrations, we also found that synthetic covering materials with a lower surface weight exhibit higher VOC value compared to higher surface weight materials.

The measured data of the emission profile of the individual tested materials were statistically evaluated. Multivariate ANOVA was used to evaluate the influence of individual monitored factors: type of material (synthetic leather) and time since the start of the chamber test (1, 3, 7, 28, and 120 days), as well as their interaction on the detected concentrations of dominant VOCs (toluene, 1,2-propanediol, limonene, TVOC), but also on the majority and minority composition of chemical substances (ethyl acetate, benzene, 1-methoxy-2-propanol, *n*-butyl acetate, ethylbenzene, *o*-xylene, octanal, and decanal). Based on the implementation of Fisher's *F* test and the detected level of significance *P*, the measured data can be considered statistically to be very significant.

An olfactometric evaluation of the emission from the tested synthetic leather samples was performed using Sniffer 9000. The device was connected to a gas chromatograph with a FID. The obtained data show that the hedonic tone of the odour was mostly recorded for substances 1-methoxy-2-propanol, benzaldehyde, and benzyl alcohol. A negative hedonic tone was determined for all the monitored substances, which means that it is an unpleasant odour. The unpleasantness of the odour (hedonic tone) varied over time, from extremely unpleasant (one day after the start of the test) to slightly unpleasant (usually after 28 days).

Synthetic leathers, the surface of which was treated with a layer of polyurethane (Ohio, Tibet), showed a higher unpleasantness of hedonic tone than materials treated with polyvinyl chloride (Vento, Vinytol). The dependence of the hedonic tone on the surface weight of the tested material was also proven, in contrast to the influence of the material composition.

The results of this study are interesting. However, the relationships between the emission, odour with the leather composition, and manufacturing process are not clear. Further analysis is needed.

**Acknowledgments:** The authors wish to thank the supports from the Specific University Research Fund of the Mendel University in Brno, Czech Republic, (Project No. FFWT\_RT\_2018002).

**Funding information:** This work was financially supported by the Specific University Research Fund of the Mendel University in Brno, Czech Republic, (No. FFWT\_RT\_2018002).

**Author contributions:** Specimen preparation, measuring VOC emissions, olfactometric assessment, data analysis, writing the manuscript, conceptualization, research project administration – P.Č.; data analysis, writing the manuscript, conceptualization, supervision, review and editing – Z.P.; data and statistical analysis, supervision, editing, writing the manuscript – M.G.; data analysis, supervision, reviewing and editing – F.K.; H.L. All authors have accepted responsibility for the entire content of this manuscript and approved its submission.

**Conflict of interest:** The authors state no conflict of interest.

**Data availability statement:** All data generated or analyzed during this study are included in this published article and its supplementary information files.

## References

- [1] Bartsch, J., E. Uhde, and T. Salthammer. Analysis of odour compounds from scented consumer products using gas chromatography-mass spectrometry and gas chromatography-olfactometry. *Analytica Chimica Acta*, Vol. 904, 2016, pp. 98–106.
- [2] Eusebio, L., M. Derudi, L. Capelli, G. Nano, and S. Sironi. Assessment of the indoor odour impact in a naturally ventilated room. *Sensors*, Vol. 17, 2017, id. 778.
- [3] Caron, F., R. Guichard, L. Robert, M. Verrielle, and F. Thevenet. Behaviour of individual VOCs in indoor environments: How ventilation affects emission from materials. *Atmospheric Environment*, Vol. 243, 2020, id. 117713.
- [4] Derbez, M., B. Berthineau, V. Cochet, M. Lethrosne, C. Pignon, J. Riberon, et al. Indoor air quality and comfort in seven newly built, energy-efficient houses in France. *Building and Environment*, Vol. 72, 2014, pp. 173–187.
- [5] Plaisance, H., J. Vignau-Laulhere, P. Mocho, N. Sauvat, K. Raulin, and V. Desauziers. Volatile organic compounds concentrations during the construction process in newly-built timber-frame houses: source identification and emission kinetics. *Environmental Science: Processes*, Vol. 19, No. 5, 2017, pp. 696–710.
- [6] Bartzis, J., P. Wolkoff, M. Stranger, G. Efthimiou, E. I. Tolis, F. Maes, et al. On organic emissions testing from indoor consumer products' use. *Journal of Hazardous Materials*, Vol. 285, 2015, pp. 37–45.
- [7] Opitz, P., S. Matysik, and O. Herbarth. Health risk assessment of indoor Volatile Organic Compounds (VOC) considering Long-term trend of VOC. *Journal of Environmental and Occupational Science*, Vol. 6, 2017, pp. 34–39.
- [8] Du, Z., J. Mo, Y. Zhan, and Q. Xu. Benzene, toluene and xylenes in newly renovated homes and associated health risk in Guangzhou, China. *Building and Environment*, Vol. 72, 2014, pp. 75–81.
- [9] Sun, X., J. HE, and X. Yang. Human breath as a source of VOCs in the built environment, Part II: Concentration levels, emission rates and factor analysis. *Building and Environment*, Vol. 123, 2017, pp. 437–445.
- [10] Liang, W., C. Yang, and X. Yang. Long-term concentrations of volatile organic compounds in a new apartment in Beijing, China. *Building and Environment*, Vol. 82, 2014, pp. 693–701.
- [11] Wang, H., Z. Xiang, L. Wang, S. Jing, S. Lou, S. Tao, et al. Emissions of volatile organic compounds (VOCs) from cooking and their speciation: A case study for Shanghai with implications for China. *Science of the Total Environment*, Vol. 621, 2018, pp. 1300–1309.
- [12] Wang, Q., B. Zeng, J. Shen, and H. Wang. Effect of lacquer decoration on VOCs and odor release from *P. neurantha* (Hemsl.) Gamble. *Scientific Reports*, Vol. 10, 2020, id. 9565.
- [13] Adamova, T., J. Hradecky, and M. Panek. Volatile Organic Compounds (VOCs) from wood and wood-based panels: methods for evaluation, potential health risks, and mitigation. *Polymers*, Vol. 12, No. 10, 2020, pp. 2289–2309.
- [14] Wolkoff, P. Indoor air humidity, air quality, and health – An overview. *International Journal of Hygiene and Environmental Health*, Vol. 221, No. 3, 2018, pp. 376–390.
- [15] Laor, Y., D. Parker, and T. Page. Measurement, prediction, and monitoring of odors in the environment: a critical review. *Reviews in Chemical Engineering*, Vol. 30, No. 2, 2014, pp. 139–166.
- [16] Yi, Q., J. Liu, G. Wang, and Y. Zhang. Evaluation of indoor air quality based on qualitative, quantitative and olfactory analysis. *Chinese Science Bulletin*, Vol. 58, No. 9, 2013, pp. 986–991.
- [17] Peng, C., C. Lan, and T. Wu. Investigation of indoor chemical pollutants and perceived odor in an area with complaints of unpleasant odors. *Building and Environment*, Vol. 44, No. 10, 2009, pp. 2106–2113.
- [18] Tagiyeva, N., S. Sean Semple, G. Devereux, and A. Sheikh. Volatile organic compounds and risk of asthma and allergy: a systematic review. *European Respiratory Review*, Vol. 24, No. 135, 2015, pp. 92–101.
- [19] Desauziers, V., D. Bourdin, H. Plaisance, and P. Mocho. Innovative tools and modeling methodology for impact prediction and assessment of the contribution of materials on indoor air quality. *Heritage Science*, Vol. 3, No. 1, 2015, pp. 1–8.
- [20] Liu, P., H. M. Mathisen, M. Skaten, and M. Justo Alonso. Use of membrane energy exchanger in ventilation: Odour sensory measurement. *Building and Environment*, Vol. 222, 2022, id. 109430.
- [21] Cometto-Muñiz, J. E., W. S. Cain, and M. H. Abraham. Detection of single and mixed VOCs by smell and by sensory irritation. *Indoor Air*, Vol. 14, 2004, pp. 108–117.
- [22] Liang, W. Volatile organic compounds, odor, and inhalation health risks during interior construction of a fully furnished residential unit in Nanjing, China. *Building and Environment*, Vol. 186, 2020, id. 107366.

- [23] Wu, C., J. Liu, L. Yan, H. Chen, H. Shao, and T. Meng. Assessment of odor activity value coefficient and odor contribution based on binary interaction effects in waste disposal plant. *Atmospheric Environment*, Vol. 103, 2015, pp. 231–237.
- [24] Hau, K. M. Quantitative structure-activity relationships (QSARs) for odor thresholds of volatile organic compounds (VOCs). *Indoor Air*, Vol. 8, No. 1, 1998, pp. 23–33.
- [25] Liu, Y., X. Qin, W. Wang, Y. Hu, D. Yuan, and X. Zhu. Identification and characterization of odorous volatile organic compounds emitted from wood-based panels. *Environmental Monitoring and Assessment*, Vol. 192, No. 6, 2020, pp. 1–10.
- [26] Salthammer, T., N. Schulz, R. Stolte, F. Monegel, and E. Uhde. Sensory evaluation in test chambers: Influences of direct and indirect assessment. *Building and Environment*, Vol. 172, 2020, id. 106668.
- [27] Wang, Q., J. Shen, Y. Shao, H. Dong, Z. Li, and X. Shen. Volatile organic compounds and odor emissions from veneered particleboards coated with water-based lacquer detected by gas chromatography-mass spectrometry/olfactometry. *European Journal of Wood*, Vol. 77, No. 5, 2019, pp. 771–781.
- [28] Félix, J. S., C. Domeño, and C. Nerín. Characterization of wood plastic composites made from landfill-derived plastic and sawdust: Volatile compounds and olfactometric analysis. *Waste Management*, Vol. 33, No. 3, 2013, pp. 645–655.
- [29] Boeker, P., J. Leppert, and P. S. Lammers. Comparison of odorant losses at the ppb-level from sampling bags of nalophan™ and tedlar™ and from adsorption tubes. *Chemical Engineering Transactions*, Vol. 40, 2014, pp. 157–162.
- [30] McGinley, M. A. and C. M. McGinley. Comparison of field olfactometers in a controlled chamber using hydrogen sulfide as the test odorant. *Water Science and Technology*, Vol. 50, No. 4, 2004, pp. 75–82.
- [31] Ontañón, I., J. Téllez, V. Ferreira, and A. Escudero. Air inside a dishwasher: Odour characterization and strategy for measuring odour changes. *Flavour and Fragrance Journal*, Vol. 34, No. 2, 2019, pp. 75–89.
- [32] Liu, R., C. Wang, A. Huang, and B. Lv. Characterization of Odors of Wood by Gas Chromatography-Olfactometry with Removal of Extractives as Attempt to Control Indoor Air Quality. *Molecules [online]*, Vol. 23, No. 1, 2018, pp. 203–212.
- [33] Wiedmer, C., C. Velasco-schön, and A. Buettner. Characterization of odorants in inflatable aquatic toys and swimming learning devices-which substances are causative for the characteristic odor and potentially harmful? *Analytical*, Vol. 409, No. 16, 2017, pp. 3905–3916.
- [34] Xu, B., Y. Wang, D. Guo, Y. Gao, W. Liu, W. Wu, et al. Determination of the key parameters of VOCs emitted from multi-layer leather furniture using a region traversal approach. *Science of the Total Environment*, Vol. 819, 2022, pp. 1–10.
- [35] Gallego, E., F. J. Roca, J. F. Perales, and X. Guardino. Comparative study of the adsorption performance of a multi-sorbent bed (Carbotrap, Carbopack X, Carboxen 569) and a Tenax TA adsorbent tube for the analysis of volatile organic compounds (VOCs). *Talanta*, Vol. 81, No. 3, 2010, pp. 916–924.
- [36] ISO 16000-6, 2021. *Indoor air – Part 6: Determination of organic compounds (VOC, VOC, SVOC) in indoor and test chamber air by active sampling on sorbent tubes, thermal desorption and gas chromatography using MS or MS FID*, Beuth Verlag, Berlin.
- [37] Brodzik, K., J. Faber, D. Łomankiewicz, and A. Gołda-Kopek. In-vehicle VOCs composition of unconditioned, newly produced cars. *Journal of Environmental Sciences*, Vol. 26, No. 5, 2014, pp. 1052–1061.
- [38] Corbi, O., A. Baratta, I. Corbi, F. Tropeano, and E. Liccardo. Design issues for smart seismic isolation of structures: past and recent research. *Sustainable Structures*, Vol. 1, No. 1, 2021, id. 000001.
- [39] Xiao, J., H. Liu, T. Ding, and G. Ma. 3D printed concrete components and structures: an overview. *Sustainable Structures*, Vol. 1, No. 2, 2021, id. 000006.
- [40] Dauletbek, A., H. Li, Z. Xiong, and R. Lorenzo. A review of mechanical behavior of structural laminated bamboo lumber. *Sustainable Structures*, Vol. 1, No. 1, 2021, id. 000004.
- [41] Xu, B., X. Chen, and J. Xiong. Air quality inside motor vehicles' cabins: A review. *Indoor and Built Environment*. Vol. 27, No. 4, 2018, pp. 452–465.
- [42] González-Martín, J., N. J. R. Kraakman, C. Pérez, R. Lebrero, and R. Muñoz. A state-of-the-art review on indoor air pollution and strategies for indoor air pollution control. *Chemosphere*, Vol. 262, 2021, id. 128376.
- [43] Su, J., H. Li, Z. Xiong, and R. Lorenzo. Structural design and construction of an office building with laminated bamboo lumber. *Sustainable Structures*, Vol. 1, No. 2, 2021, id. 000010.
- [44] Liua, K., D. Jayaramana, Y. Shib, K. Harriesc, J. Yangb, W. Jina, et al. “Bamboo: A very sustainable construction material” - 2021 International online seminar summary report. *Sustainable Structures*, Vol. 2, No. 1, 2022, id. 000015.
- [45] Zhou, Y., Y. Huang, U. Sayed, and Z. Wang. Research on dynamic characteristics test of wooden floor structure for gymnasium. *Sustainable Structures*, Vol. 1, No. 1, 2021, id. 000005.
- [46] Frank, G., S. E. Koch, D. Singer, and C. Schelle. V.O.C. Test Chamber-based Quantification Results of Upholstery Leathers Focused on Statistical Frequency Scales for TVOC and Single Compound Concentrations. *Journal of the Society of Leather Technologists and Chemists*, Vol. 100, No. 5, 2016, pp. 225–237.
- [47] Nalbat, S., E. Onem, B. Basaran, A. Yorgancioglu, and O. Yilmaz. Effect of finishing density on the physico-mechanical properties of leather. *Journal of the Society of Leather Technologists and Chemists*, Vol. 100, No. 2, 2016, pp. 84–89. <https://search.ebscohost.com/login.aspx?direct=true&db=edselc&an=edselc.2-52.0-84963800378&scope=site>.
- [48] Ponzo, F. C., D. C. Antonio, L. Nicla, and D. Nigro. Experimental estimation of energy dissipated by multistorey post-tensioned timber framed buildings with anti-seismic dissipative devices. *Sustainable Structures*, 2021, Vol. 1, No. 2, id. 000007.
- [49] Liang, R. and G. Hota. Development and evaluation of load-bearing fiber reinforced polymer composite panel systems with tongue and groove joints. *Sustainable Structures*, Vol. 1, No. 2, 2021, id. 000008.
- [50] Meng, X., D. Zhang, P. Feng, and N. Hu. Review on mechanical behavior of solar cells for building integrated photovoltaics. *Sustainable Structures*, Vol. 1, No. 2, 2021, id. 000009.
- [51] ČSN EN ISO 16000-9. *Indoor air - Part 9: Determination of volatile organic compound emissions from building materials and furniture - Test chamber method*, European Committee for Standardization, Brussels, Belgium, 2007.
- [52] Faber, J. and K. Brodzik. Air quality inside passenger cars. *AIMS Environmental Science*, Vol. 4, No. 1, 2017, pp. 112–133.
- [53] Ashraf, M., M. J. Hasan, and S. Al-Deen. Semi-rigid behaviour of stainless steel beam-to-column bolted connections. *Sustainable Structures*, Vol. 1, No. 1, 2021, id. 000002.
- [54] Wang, W., J. Wang, and L. Guo. Mechanical behavior analysis of LEM-infilled cold-formed steel walls. *Sustainable Structures*, 2022, Vol. 2, No. 1, id. 000013.

- [55] Liang, R., D. Stanislawski, and G. Hota. Material characterization and structural response under earthquake loads of hakka rammed earth building. *Sustainable Structures*, 2021, Vol. 1, No. 1, id. 000003.
- [56] Ernstgård, L., B. Sjögren, G. Johanson, A. Iregren, and U. Svedberg. Acute effects of exposure to hexanal vapors in humans. *Journal of Occupational and Environmental Medicine*. 2006, Vol. 48, No. 6, pp. 573–580.
- [57] Richter, T. M., R. M. Laing, and P. J. Bremer. Binding and release of odor compounds from textiles: Changing fiber selection for apparel. *Textile Research Journal*. 2021, Vol. 91, No. 7/8, pp. 709–716.
- [58] Han, Y., J. Hu, and Z. Xin. Facile preparation of high solid content waterborne polyurethane and its application in leather surface finishing. *Progress in Organic Coatings*. 2019, Vol. 130, pp. 8–16.
- [59] Wang, J., Z. Ma, L. Chen, H. J. Sun, and W. K. Fan. Determination of the emission of volatile organic compounds from leather seats in environmental test chamber. *Key Engineering Materials*. 2018. Vol. 768, pp. 31–35.
- [60] Lovascio, S., M. Brattoli, and M. Penza. Odour detection methods: Olfactometry and chemical sensors. *Sensors* 2011, Vol. 11, No. 5, pp. 5290–5322.
- [61] ČSN EN 13725. *Air quality - Determination of odour concentration by dynamic olfactometry*. European Committee for Standardization, Brussels, Belgium, 2003.