

SUSTAINABILITY ASSESSMENT AND REPORTING IN AGRICULTURE SECTOR

Edward Kassem¹, Oldřich Trenz¹, Jiří Hřebíček¹, Oldřich Faldík¹

¹Department of Informatics, Faculty of Business and Economics, Mendel University in Brno, 613 00 Brno, Czech Republic

Abstract

KASSEM EDWARD, TRENZ OLDŘICH, HŘEBÍČEK JIŘÍ, FALDÍK OLDŘICH. 2017. Sustainability Assessment and Reporting in Agriculture Sector. *Acta Universitatis Agriculturae et Silviculturae Mendelianae Brunensis*, 65(4): 1359–1369.

Sustainability assessment is a mainstream business activity that demonstrates the link between the organization's strategy and commitment to a sustainable global economy. Sustainability indicators describe the environmental, social, economic and governance performance of Small and Medium-sized Businesses/Enterprises (SMB/SME). Unfortunately, their implementations in the Czech Republic show a low level of engagement in sustainability assessment.

The paper presents the results of the authors' research in sustainability assessment of SMB/SMEs in the agriculture sector of the Czech Republic. An appropriate set of key performance indicators (KPIs) in four dimensions (economy, environment, social and governance) was developed to suit the SMB/SMEs sustainability assessment in the agriculture sector. A set of KPIs is proposed to help SMB/SMEs to avoid the barriers of sustainability assessment. These indicators are based mainly on Sustainability Assessment of Food and Agriculture, Global Reporting Initiatives Frameworks and on current research state-of-the-art. They have been created following the analysis of a number of agricultural enterprises over the world, particularly within European countries.

Keywords: sustainability indicators, key performance indicators, agriculture, ICT, reporting, SMB/SME, SAFA, GRI.

INTRODUCTION

Sustainability assessment is a mainstream business activity that demonstrates the link between an organization's strategy and commitment to a sustainable global economy. There are many frameworks for measuring corporate performance and sustainability. Recently, the most widely used framework for sustainability reporting is GRI (Global Reporting Initiative), (G4 Guidelines 2013; Kocmanová *et al.* 2013). In addition, there are many international standards for implementing and certifying sustainability indicators like ISO 9000, ISO 14000, ISO 18000 (ISOHelpline 2014), ISO 26000 (ISO 2014) and EMAS (EMAS 2014). There are also many other specialized and popular sustainability reporting frameworks like Sustainability Assessment of Food and Agriculture (SAFA) of the Food and Agriculture Organization of the United Nations (FAO), which reports in

the Food and Agriculture sectors (SAFA Guidelines 2013; Annunziata and Scarpato 2014; Schader *et al.* 2014). Based on past research, sustainability assessment becomes the main issue. A lot of authors have tried to determine the suitable sustainability indicators and methods of performance assessment. For example Chand *et al.* (2015) have developed a multi-attribute farm-level sustainability method. It takes into account three different pillars; economic, social, and ecological, all of which are assessed in the case of 120 dairy farms. The assessment was done by computing the composite Sustainable Dairy Farming Index (SDFI). Schindler *et al.* (2015) compare different sustainability assessment methods for farming interventions and they verify whether the requirements of the sustainability impact assessment theory are fulfilled. As an output of this work, a set of indicators for the sustainability impact assessment framework is considered. James *et al.* (2012) has described the trend of global

sustainability and integrated reporting guidelines and later also discussed the opportunities for SMB/SMEs for adopting the integrated sustainability reports and providing successful strategies of doing that. Jeníček (2013) has evaluated the present indicators on the example of economic indicators, all of this on the national and international level. Nikolaou and Tsalis (2013) have suggested a new scoring method which uses GRI indicators (G4 Guidelines 2013) to measure the corporate sustainability performance by drawing data from corporate sustainability reports. This method was tested using a sample of Greek firms. Samuel *et al.* (2013) have also depended on GRI guidelines for the assessment of sustainability performance. These authors take into consideration three dimensions of the GRI framework: Environment; Economics; and Social (Society, Human Rights, Labor Practices and Decent Work and Product Responsibility). The study was carried out using the questionnaire and interviews of Malaysian enterprises. Tokos *et al.* (2012) have proposed a methodology for integrated performance assessment in the breweries sector. It depends on the environmental, societal, economic, and integrated indicators which reflect the characteristics of the brewing industry. This methodology can be used for benchmarking breweries against performance, providing benchmark values for each indicator.

Sustainability reporting on the food and agriculture sector (G4-Food-Processing-Sector-Disclosures 2014; SAFA Tools 2014; Hřebíček *et al.* 2015) is an important business activity that demonstrates the link between the enterprise strategy and commitment to a sustainable global economy. It engages companies in disclosure of their economic, environmental, social, and governance (ESG) impacts and efforts (Kocmanová *et al.* 2013). This engagement is summarized by helping the organizations in understanding, measuring and communicating their main four performance pillars (economic, environmental, social and governance) (G4 Guidelines 2013, SAFA Guidelines 2013). They can provide an early warning, in time to prevent economic, social and environmental damage. Primarily, only the large companies have been involved in sustainability reporting practices. Unfortunately, the Czech Republic's sustainability reporting implementation shows a low level of engagement in sustainability assessment. Because of the important effects of Small and Medium-sized Businesses/Enterprises (SMB/SME) that impact the European economy, they need a method or procedure to measure, control and improve their sustainable performance. Such a procedure for effective and efficient management should be simple, efficient and should integrate these various viewpoints of the performance in environmental, economic and social terms (Chand *et al.* 2015, Tokos *et al.* 2012). The importance and exploitation of these approaches in the agriculture sector and the appropriate combination of information and

communication technologies (ICT) is discussed Hennyeyová *et al.* (2010).

The goal of the paper is to introduce an appropriate set of key performance indicators (KPIs) in four dimensions (economy, environment, social and governance) which was developed to suit the SMB/SMEs sustainability assessment in the agriculture sector and will help SMB/SMEs to avoid the barriers of sustainability assessment together with developed WEBRIS web information system for sustainability reporting in SMB/SMEs. The paper consists of several parts. We discuss, in the Materials and Methods section, a sustainability assessment framework and a proposal of the web information system WEBRIS. We conclude our paper, in the Results and Discussion section, with a proposed set of appropriate key performance indicators which, having been applied to our WEBRIS web information system, helped Czech agriculture companies in performing quick and efficient sustainability assessment.

MATERIALS AND METHODS

In this section, we concentrate on the most familiar and widely-used frameworks for agriculture enterprises that have been adopted worldwide. We have been following these verified GRI and SAFA frameworks (G4-Food-Processing-Sector-Disclosures, 2014; SAFA Guidelines, 2013) in order to choose the most suitable KPIs for our WEBRIS web information system Hřebíček *et al.* (2015). A good sustainability assessment depends not only on the quantity but also on the quality of information in the sustainability report. To achieve the desired quality, the reporter should pay attention for the following points G4 Guidelines (2013):

- The sustainability report should reflect not only the positive but also the negative aspects of the organization under scrutiny.
- The reports should be accurate and prepared in a way that allows for stakeholders to analyze changes in the organization's performance over time.
- A regular time schedule should be assigned for each report.
- The information included in the sustainability report should be understandable, reliable, transparent, and accessible.

For these reasons, our long time research (Kocmanová *et al.* 2013; Hřebíček *et al.* 2013a, 2013b, 2015) combines KPIs based on two frameworks: Sustainability Assessment of Food and Agriculture (SAFA Guidelines 2013) and Global Reporting Initiatives (G4 Guidelines 2013; G4-Food-Processing-Sector-Disclosures 2014). This enables us to choose the most commonly used KPIs for the agriculture sector.

The last version of the GRI G4 Guidelines consists of two parts: the Reporting Principles and

the Standard Disclosures and the Implementation Manual. The Reporting Principles and the Standard Disclosures guidance explain the reporting requirements of reporting against the framework, i.e., 'what' must be reported. The Implementation Manual provides further guidance on 'how' organizations can report against G4 criteria. The improvement of the technical quality of the guidelines content was focused on the elimination of ambiguities and differing interpretations. Furthermore, this improvement was focused on the harmonization of guidelines with other internationally accepted standards, and on offering guidance related to linking the sustainability reporting process to the preparation of an Integrated Report (James *et al.* 2012; Samuel *et al.* 2013; Schader *et al.* 2014).

The SAFA was designated for the assessment of sustainability along food and agriculture value chains (SAFA Guidelines, 2013; Hřebíček *et al.* 2013a, SAFA Tools, 2014; Annunziata and Scarpato, 2014; Schader *et al.* 2014). It is one of the most important concepts that should be taken into consideration when informing society about the progress made in the economic, social, environmental and governance areas. This framework can be applied to SMB/SMEs and large-scale companies, organizations and other stakeholders that participate in crop, livestock, forestry, and fishery value chains.

The SAFA framework seeks to harmonize the long-term objective of sustainable transformation of corporate agriculture and food systems, providing a transparent and aggregated framework designed for assessing corporate sustainability. Its structure is built upon a combination of various standards and frameworks like: ISO 14040:2006, the ISEAL Code of Good Practice, the Reference Tools of the Global Social Compliance Programme (GSCP 2010), the GRI G4 Sustainability Reporting Guidelines and its Food Sector Supplement (G4-Food-Processing-Sector-Disclosures 2014). The guiding vision of the SAFA framework is that food and agriculture systems worldwide are characterized by four dimensions of sustainability: good governance, environmental integrity Ahodo and Svatonova (2014), economic resilience and social well-being. The SAFA framework consists of four nested levels that are supposed to mutually enhance their own coherence Schader *et al.* (2014). These four levels begin with the highest level of the SAFA framework, which encompasses many aspects by means of aggregating four dimensions of sustainability. The second level of the SAFA framework contains a set of 21 core sustainability issues or universal "themes". At this level, policy-makers and national governments can work towards the alignment and harmonization of a holistic scope of sustainability without defining the specific pathways. On the third level of the SAFA framework, each of the 21 sustainability themes is divided into sub-themes, or individual

issues within SAFA themes. This level is composed of 56 sub-themes, is relevant for the supply chain actors doing a contextualization analysis, which identifies hot spot areas, as well as gaps in existing sustainability efforts.

Based on a comprehensive study of more than 65 agriculture companies over the world together with above GRI and SAFA framework, a set of the most widely used KPIs was extracted.

One of the problems faced by sustainability reporting is the processing of massive corporate data to a household term that refers to not just the volume but also the variety, veracity and velocity of change. The quick and effective management of this data becomes the main challenge for the implementation of the ICT system architecture. For this purpose, many different solutions are suggested. Shahi *et al.* (2012) builds a software system to automate the scoring process of sustainability assessment. This software has been developed by applying the machine learning approach to text classification. Two technologies: Business Intelligence (BI) technology and extensible business reporting language (XBRL) (Engel *et al.* 2003; XBRL 2012) are used. This ICT has the advantage of quickly and easily optimizing the data-extraction process from the central database. Kubata *et al.* (2015) evaluate the current state of BI and the relevant business information systems and software for the agriculture sector in the Czech Republic. A survey of 135 farms from various regions of the Czech Republic was done. The output of the exploratory analysis of the survey showed that only 1% of the farms use BI application. For that reason, the standardized data warehouse model designed for sustainability reporting based on the specific XBRL taxonomy and the known dimensions (Hamscher *et al.* 2005; Piechocki *et al.* 2007) is depicted in Fig. 1. Its three components are the XBRL Processor, the XBRL Gate and the Business Intelligence ETL/Replication component. To completely cover any amount of data (including the Big Data), each of the components must be multi-tenant and highly scalable. This design supports the Software as a Service (SaaS) cloud environment as well as, primarily, the Private Cloud Hodinka *et al.* (2014).

Finally, we made a survey of different Czech agriculture companies using a WEBRIS system (Hřebíček *et al.* 2015) that has been developed. WEBRIS is a combination of different information and communication technologies (ICT) which can be used for quick and efficient data aggregation and assessment. Some approaches of artificial intelligence (Štastný, Škorpil, 2007), Data Envelopment Analysis (Wang Y. M., Chin K. S. 2010), were used for the purpose of sustainability assessment. The structure of the WEBRIS system is implemented as a combination of above BI technology and XBRL. We have used WEBRIS web system in our survey and also in companies' benchmarking. This web system can be used not

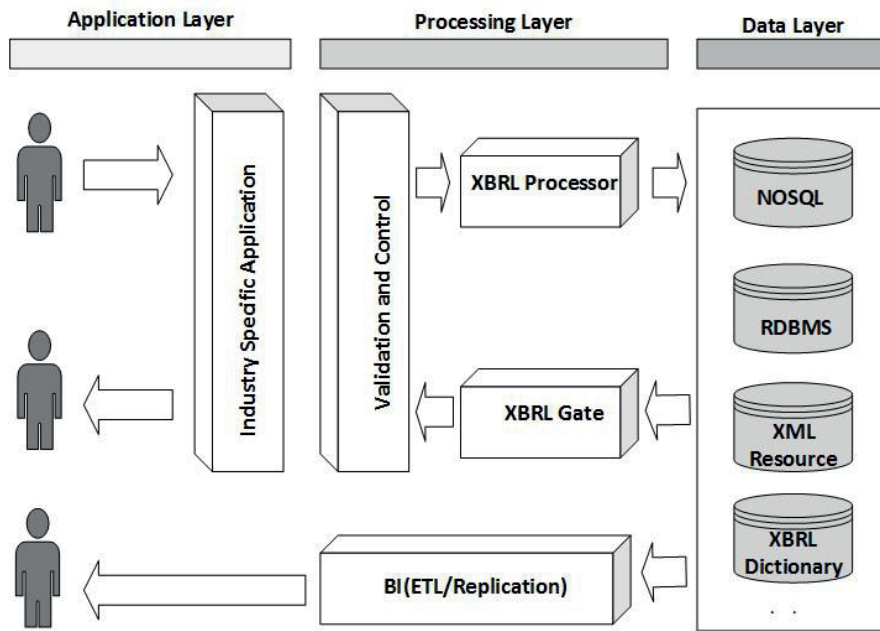

1: Proposed Processing Architecture (Hodinka et al. 2014)

only for the purposes of reporting, but also for the data discovery discipline Hřebíček et al. (2015).

RESULTS AND DISCUSSION

In this section, we will also present the results of our research and the analysis of the state-of-the-art of sustainability assessment in Czech Republic. The goal of our research can be summarized in several points:

- Determining the current state of the KPIs which are being used in sustainability assessment.

- Finding the barriers that make the sustainability reporting for SMB/SME a challenging process.

- Solving this drawback to encourage SBM/SMEs in sustainability reporting.

The two previously described frameworks (GRI and SAFA) present a lot of indicators related

to the economic, environmental, social, and governance pillars. Reporting on all these indicators is a big challenge, because collecting and managing data is a very difficult and expensive process. Due to this, we have been trying to determine the more appropriate set of these indicators by doing quantitative research about the most frequently used indicators in each dimension. Our research has concentrated on determining a more appropriate set of KPIs for agriculture enterprises in the Czech Republic. We have drawn upon the available GRI database to achieve our first goal of choosing the KPIs of economic, social, and environmental dimensions. This default database consists of approximately 67 reports for different enterprises around the world: out of this total, 41 reports concern European agriculture companies. Figures 2, 3 and 4 illustrate the indicator application

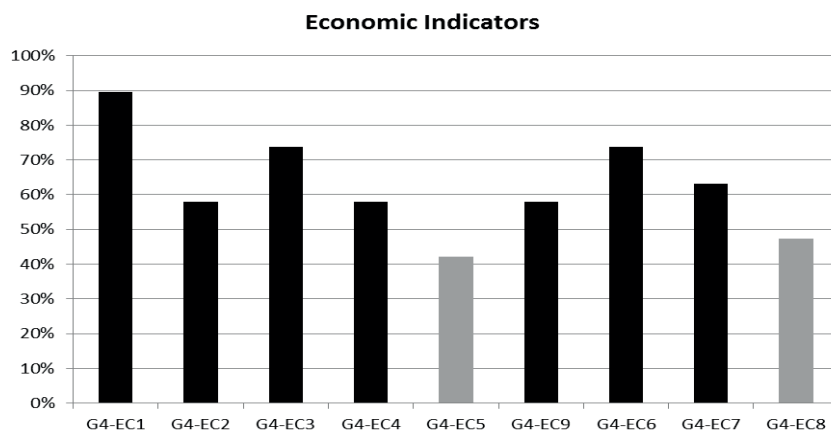

2: Economic Indicators According to their Application in Reports. Source: Authors

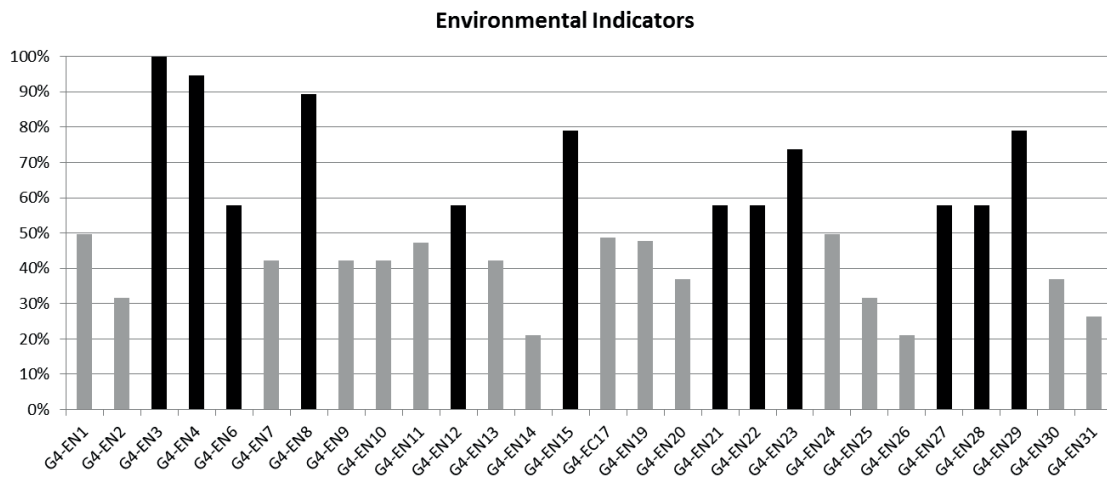

3: Environmental Indicators According to their Usage in Reports. Source: Authors

percentage as exercised in the abovementioned worldwide reports. In Fig. 2, all the economic indicators are described. The most often used indicators (in black) are selected for further analysis according to the threshold of 50% (Yegbemey *et al.* 2014).

Fig. 3 depicts the statistical results of the most relevant environmental indicators in agriculture enterprises around the world. In this case, the threshold of 50% is taken into consideration (Yegbemey *et al.* 2014).

Fig. 4 presents the social indicators which are used for sustainability assessment. These indicators are aggregated into four main sets: Labor practice and decent work, human rights, society and product responsibility. The 50% threshold has been selected for the purposes of the next analysis (Yegbemey *et al.* 2014).

As mentioned above, we have tried to cover all the dimensions of sustainability assessment. The first three pillars are studied above but the fourth one isn't mentioned in the GRI framework. For this reason, in order to implement

a full set of sustainability indicators, we depend on the governance indicators presented in the SAFA framework. The first analysis has allowed us to generate Tab. I. It consists of 56 key indicators in different dimensions that could be used for sustainability assessment.

Having described the most relevant indicators in Tab. I, we tested them in a survey. The survey involved 30 Czech agriculture companies. The respondents were given a web-based questionnaire in the WEBRIS system and we conducted several interviews with them. The efficiency of randomly chosen company from our survey is presented in Fig. 5. Only the main indicators are presented for better visualization. It depicts the company's performance, comparing it with the determined maximum value of the indicators in the studied sector.

This figure depicts the "68%" efficiency of a random Czech agriculture company which participated in the questionnaires process. By performing this survey, we have been trying to select from the 56 previously mentioned KPIs the most

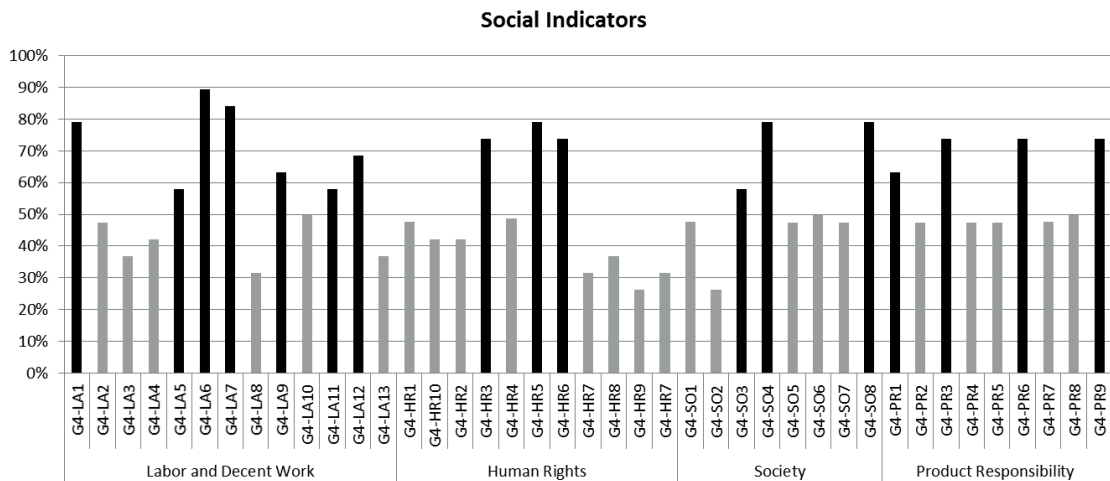

4: Social Indicators According to their Usage in Reports. Source: Authors

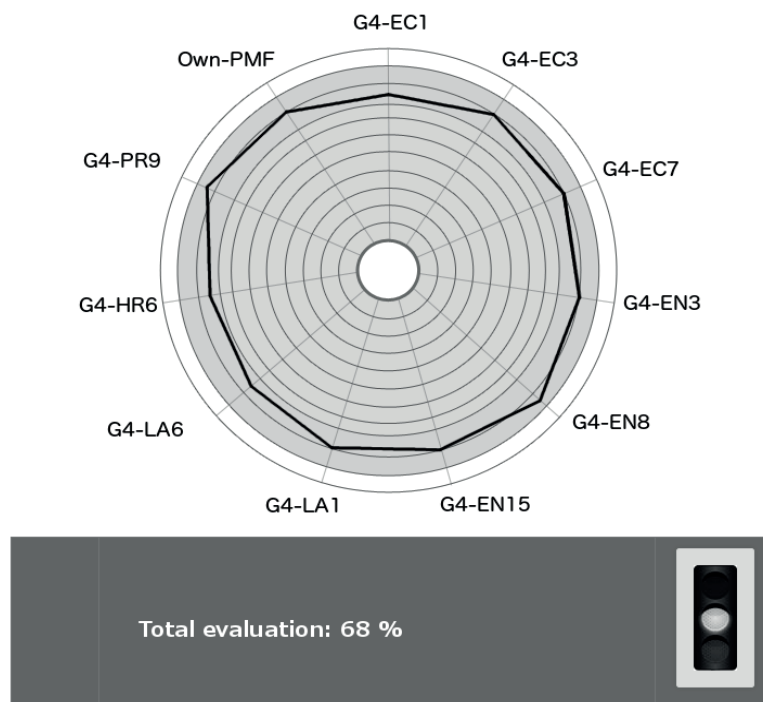

5: The Rating of a Random Czech Agriculture Company, According to our Survey. Source: Authors

relevant ones in terms of availability and importance for Czech agriculture companies. For these reasons, the Chi-square test was applied. This test can be used when you have one categorical variable from a single population. It was used to determine whether

the sample data are consistent with a hypothesized distribution (Black 2014). There are two possible answer categories, relevant (fully used or partly used in the report) or not relevant (not used in the report) that are available. In order to apply the Chi-square

I: KPIs for Agriculture Enterprises in the Czech Republic. Source: Authors.

Theme	Sub-theme	Indicator	
Economic dimension	Economic performance	G4-EC1	
		G4-EC2	
		G4-EC3	
	Market presence	G4-EC6	
		G4-EC7	
	Indirect economic impacts	G4-EC8	
	Procurement Practices	G4-EC9	
	Environmental dimension	Energy	G4-EN3
			G4-EN4
G4-EN6			
Water		G4-EN8	
Biodiversity		G4-EN12	
Emissions		G4-EN15	
Effluents and waste		G4-EN21	
		G4-EN22	
		G4-EN23	
Products and Services		G4-EN27	
	G4-EN28		
Compliance	G4-EN29		

	Theme	Sub-theme	Indicator
Social dimension	Labor Practices and Decent Work	Employment	G4-LA1
			G4-LA5
		Occupational health and safety	G4-LA6
			G4-LA7
		Training and Education	G4-LA9
		G4-LA11	
		Diversity and Equal Opportunity	G4-LA12
	Human Rights	Non-discrimination	G4-HR3
		Child labor	G4-HR5
		Forced and compulsory labor	G4-HR6
	Society	Public Policy	G4-SO3
			G4-SO4
		Compliance	G4-SO8
	Product Responsibility	Customer Health and Safety	G4-PR1
Product and service labeling		G4-PR3	
Marketing communication		G4-PR6	
Compliance		G4-PR9	
Governance dimension	Corporate Ethics	Mission statement	SAFA-G 1.1.1
			SAFA-G 1.1.2
		Due diligence	SAFA-G 1.2.1
	Accountability	Holistic audits	SAFA-G 2.1.1
		Responsibility	SAFA-G 2.2.1
		Transparency	SAFA-G 2.3.1
	Participation		SAFA-G 3.1.1
		Stakeholder Dialogue	SAFA-G 3.1.2
			SAFA-G 3.1.3
			SAFA-G 3.1.4
		Grievance procedures	SAFA-G 3.2.1
		Conflict resolution	SAFA-G 3.3.1
		The percentage of males and fe-males	Own-PMF
	Rule of Law	Legitimacy	SAFA-G 4.1.1
		Remedy, restoration and prevention	SAFA-G 4.2.1
		Civic responsibility	SAFA-G 4.3.1
			SAFA-G 4.4.1
Holistic Management	Resource appropriation	SAFA-G 4.4.2	
	Sustainability management plan	SAFA-G 5.1.1	
	Full-cost accounting	SAFA-G 5.2.1	

test with the degree of freedom $fe = 1$, two possible hypotheses were formulated:

- Hypothesis 0 – All indicators are relevant, and
- Hypothesis 1 – Not all indicators are relevant.

The responses were tested against a significance value $p < 0.05$, since $\chi^2 = 3,841$ and $fe = 1$. The most usable and reported KPIs according to Czech agriculture companies which involved into our survey and depending on the results achieved in the previous research project “Construction of Methods for Multifactor Assessment of Company Complex Performance in Selected Sectors No. P403/11/2085” (Kocmanová *et al.* 2013) of the Czech

Science Foundation. This group consists of 7 economic, 12 environmental, 17 social and 20 governance KPIs. The survey involves 30 Czech agriculture companies.

The result of our research is a set of 27 out of 56 indicators considered by the respondents, i.e. 48%, as listed in Tab. II. This set covers four dimensions of sustainability assessment. It consists of 3 economic (11%), 6 environmental (22%), 11 social (41%) and 7 governance (26%) KPIs which are based on the GRI G4 and SAFA frameworks. Where G4-EC1: direct economic value generated and distributed, G4-EC3: coverage of the organization's defined benefit plan obligations, G4-EC7 development and

II: *Optimized Set of KPI for Agriculture Enterprises in the Czech Republic. Source: Authors.*

Theme	Sub-theme	Indicator	Unit	Significance	
Economic dimension	Economic performance	G4-EC1	CZK	0.0006	
		G4-EC3	CZK	0.0389	
	Indirect economic impacts	G4-EC7	CZK	0.0389	
Environmental dimension	Energy	G4-EN3	GWh/CZK	0.00001	
		G4-EN4	GWh/CZK	0.0001	
	Water	G4-EN8	t/CZK	0.0005	
	Emissions	G4-EN15	t/CZK	0.0116	
		G4-EN23	t/CZK	0.0389	
Social dimension	Labor Practices and Decent Work	Compliance	G4-EN29	yes/no	0.0116
		Employment	G4-LA1	num	0.0116
			G4-LA6	num	0.0006
	Human Rights		G4-LA7	num	0.0029
		Non-discrimination	G4-HR3	yes/no	0.0389
		Child labor	G4-HR5	yes/no	0.0116
		Forced and compulsory labor	G4-HR6	num	0.0389
			G4-SO4	yes/no	0.0116
		Compliance	G4-SO8	yes/no	0.0116
		Product and service labeling	G4-PR3	yes/no	0.03895
Marketing communication	G4-PR6	yes/no	0.03895		
Governance dimension	Corporate Ethics	Compliance	G4-PR9	CZK	0.03895
		Mission statement	SAFA-G 1.1.1	yes/no	0.00001
	Accountability	Holistic audits	SAFA-G 2.1.1	yes/no	0.0389
			SAFA-G 3.1.2	yes/no	0.0389
		Grievance procedures	SAFA-G 3.2.1	yes/no	0.0116
		The percentage of males and females	Own-PMF	%	0.00001
Remedy, restoration and prevention	SAFA-G 4.2.1	yes/no	0.0116		
Full-cost accounting	SAFA-G 5.2.1	yes/no	0.03895		

impact of infrastructure investments and services supported, G4-EN3: energy consumption within the organization, G4-EN4 energy consumption outside of the organization, G4-EN8 total water withdrawal by source, G4-EN15 direct greenhouse gas (GHG) emission, G4-EN23 total weight of waste by type and disposal method, G4-EN29 monetary value of significant and total number of non-monetary sanctions for non-compliance with environmental laws and regulations, G4-LA1 total number and rates of new employee hires and employee turnover by age group, gender, and region, G4-LA6 type of injury and rates of injury, occupational diseases, lost days, and absenteeism, and total number of work-related fatalities, by region and by gender, G4-LA7 workers with high incidence or high risk of diseases related to their occupation, G4-HR3 total number of incidents of discrimination and corrective actions taken, G4-HR5 operations and suppliers identified as having significant risk for incidents of child labor, and measures taken to contribute to the effective abolition of child labor, G4-HR6 operations and suppliers identified as having significant risk for incidents of forced or compulsory labor, and measures to contribute to

the elimination of all forms of forced or compulsory labor, G4-SO4 communication and training on anti-corruption policies and procedures, G4-SO8 monetary value of significant fines and total number of non-monetary sanctions for non-compliance with laws and regulations, G4-PR3 type of product and service information required by the organization's procedures for product and service information and label in, G4-PR6 sale of banned or disputed products, G4-PR9 monetary value of significant fines for non-compliance with laws and regulations concerning the provision and use of products and services. By answering the following questions the company can fill out SAFA group of indicators. SAFA-G 1.1.1: is the mission of the enterprise articulated in all enterprise reporting and understood by all employees or members?, SAFA-G 2.1.1 does the enterprise use an internationally recognized framework for sustainability reporting such as the Global Reporting Initiative, or is social auditing being used by the enterprise, SAFA-G 3.1.2 does the enterprise use appropriate mechanisms to engage with each group of stakeholders?, SAFA-G 3.2.1 can the enterprise describe grievance procedures for each stakeholder group, how they

are publicized (especially with “least powerful” stakeholders) and their current usage?, Own-PMF the percentage of males and females, SAFA-G 4.2.1 can the enterprise show evidence of a prompt and responsible response to legal, regulatory, international human rights and voluntary code breaches, including detailed response on how the breach was remedied, how the effects of the breach will be restored or compensated, and the policies and processes instituted to prevent further breaches?, and SAFA-G 5.2.1 is the business success of the enterprise measured and reported to stakeholders taking into account direct and indirect impacts on the economy, society and physical environment. For more description and all related calculations of above mentioned KPI, review (G4 Guidelines 2013, SAFA Guidelines 2013).

In additional they are accepted by Czech companies. Some of them have two values (yes/

no) whereas others can take different values according to the company effects. Comparing the last two above mentioned tables, we can conclude that in fact 43% of the economic indicators are considered important for this significance level. For the environmental category, 50% are considered important and for the social category, 65% are considered relevant. Finally, approximately 35% of the governance indicators are important. The achieved results can be used for sustainability assessment of the agriculture sector in the Czech Republic. They can be used as bases of the WEBRIS web portal Hřebíček *et al.* (2015) to support corporate sustainability assessment and reporting in the selected subject area, namely the area of the SMB/SMEs in the agriculture sector in the Czech Republic.

CONCLUSION

The principle of sustainability assessment and reporting is important for SMB/SME management. Based on sustainability assessment, several important steps should be taken. This process can begin once the weak points of each SMB/SME are determined, and it ends when the best solution to achieving sustainable performance of SMB/SMEs has been found. Because of that, sustainability assessment should be a comprehensive process. This fact has led us to use several dimensions for the purposes of this assessment. It depends on the environmental, social, economic and governance dimensions that include various KPIs suggested by different resources (frameworks and researches). Some of these resources have focused on one dimension, others on more, but all of them propose a large set of KPIs.

SMB/SMEs have significant impacts on the European economy, employment and environment; they, however, show a fairly low level of engagement in sustainability assessment. This is happening due to many barriers that the SMB/SMEs come across, which makes sustainability assessment a very challenging process. Because of the important effects that SMB/SMEs have on the European economy, there is need for a simple, efficient method or procedure that would measure, control and improve their performance. This paper aims to solve the abovementioned drawbacks and achieves the goal by applying two main frameworks (GRI G4 and SAFA), each of them suggesting different KPIs. The authors have chosen the most widely used indicators, based on the quantitative reports study done for more than 65 agricultural companies around the world. After that, a survey of 30 Czech companies has been performed. Drawing on the survey and taking into consideration the results of the “Construction of Methods for Multifactor Assessment of Company Complex Performance in Selected Sectors No. P403/11/2085” project that has been solved previously, the most available and efficient KPIs are proposed. This set of chosen indicators is used in the new WEBRIS web information system designated for SMBs/SMEs’ sustainability assessment of the Czech agriculture sector. This WEBRIS can also help different SMB/SMEs to communicate with each other more easily and efficiently, to establish and maintain business relationships, and to provide an active participation in their decision-making. As a future work we are planning to extend WEBRIS system to be used for different companies despite their sectors. All small and medium companies will be able to easily calculate their sustainability and compare it with others. Then specifying their weak points, they will be able to determine the ways to solve them.

Acknowledgements

This paper is supported by the Czech Science Foundation. Project name: Measuring corporate sustainability performance in selected sectors [Nr. 14-23079S] and Modelling and simulation of sustainable investment decision-making [17-23448S].

REFERENCES

- AHODO, K. and SVATONOVÁ, T. 2014. The use of economic instruments in environmental policies to mitigate diffuse pollution from agriculture. *Agric. Econ. – Czech*, 60(2): 74–81.
- ANNUNZIATA, A. and SCARPATO, D. 2014. Factors affecting consumer attitudes towards food products with sustainable attributes. *Agric. Econ. – Czech*, 60(8): 353–363.
- BLACK, K. 2014. *Business Statistics for Contemporary Decision Making*. 8th Edition. John Wiley & Sons, Inc.
- CHAND, P., SIROHI, S. and SIROHI, S. K. 2015. Development and application of an integrated sustainability index for small-holder dairy farms in Rajasthan, India. *Ecological Indicators*, 56: 23–30.
- EUROPEAN COMMISSION. 2014. *EMAS – EU Eco-Management and Audit Scheme*. [Online]. Available at: http://ec.europa.eu/environment/emas/index_en.htm [Accessed: 2016, November 01].
- EENGEN, P., HAMSCHEER, W., SHUETRIM, G. and KANNON, D. V. and WALLIS, H. 2003. *Extensible Business Reporting Language (XBRL)*, 2.1. XBRL International. [Online]. Available at: <http://www.xbrl.org/Specification/XBRL-RECOMMENDATION-2003-12-31+Corrected-Errata-2008-07-02.htm> [Accessed: 2016, November 11].
- FREHE, V., STIEL, F. and TEUTEBERG, F. 2014. A Maturity Model and Web Application for Environmental Management Benchmarking. In: *Twentieth Americas Conference on Information Systems*. Savannah, United States, p. 1–14.
- GLOBAL REPORTING INITIATIVE. 2013. *Reporting principles and standard disclosures. Implementation manual. G4 Guidelines*. [Online]. Available at: <https://www.globalreporting.org/resourcelibrary/GRI4-Part1-Reporting-Principles-and-Standard-Disclosures.pdf> [Accessed: 2016, November 08].
- GLOBAL REPORTING INITIATIVE. 2014. *Food Processing. Sector Disclosures*. [Online]. Available at: <https://www.globalreporting.org/resourcelibrary/GRI-G4-Food-Processing-Sector-Disclosures.pdf> [Accessed: 2016, November 08].
- GLOBAL REPORTING INITIATIVE. 2013. *GRI Taxonomy Implementation Guide*. [Online]. Available at: <https://www.globalreporting.org/resourcelibrary/GRI-Taxonomy-2013-Architecture-Style-Guide.pdf> [Accessed: 2016, November 08].
- GSCP. 2010. Reference tools of the global social compliance programme. [Online]. Available at: <http://www.gscpnet.com/working-plan.html>. [Accessed: 2016, November 09].
- HAMSCHEER, W., GOODHAND, M., HOFFMAN, C., HOMER, B., MACDONALD, J., SHUETRIM, G. and WALLIS, H. 2005. *Financial Reporting Taxonomies Architecture 1.0*, XBRL International. [Online]. Available at: <http://www.xbrl.org/technical/guidance/FRT-RECOMMENDATION-2005-04-25+corrected-errata-2006-03-20.rtf> [Accessed: 2016, August 07].
- HENNYEYOVÁ, K. and DEPEŠ, P. 2010. Analysis of the exploitation of information and communication technologies in the agri-food sector companies. *Agric. Econ. – Czech*, 56(10): 403–408.
- HODINKA, M., ŠTENCL, M., HŘEBÍČEK, J. and TRENZ, O. 2014. Business intelligence in environmental reporting powered by XBRL. *Acta Universitatis Agriculturae et Silviculturae Mendelianae Brunensis*, 62(2): 355–362.
- HŘEBÍČEK, J., TRENZ, O. and VERNEROVÁ, E. 2013a. Optimal set of agri-environmental indicators for the agricultural sector of Czech Republic. *Acta Universitatis Agriculturae et Silviculturae Mendelianae Brunensis*, 61(7): 2171–2181.
- HŘEBÍČEK, J., VALTINYOVÁ, S., KŘEN, J., HODINKA, M., TRENZ, O. and MARADA, P. 2013b. Sustainability indicators: development and application for the agriculture sector. In: *Sustainability Appraisal: Quantitative Methods and Mathematical Techniques for Environmental Performance Evaluation*. Springer Berlin Heidelberg, p. 63–102.
- HŘEBÍČEK, J., FALDÍK, O., KASEM, E. and TRENZ, O. 2015. Determinants of Sustainability Reporting in Food and Agriculture Sectors. *Acta universitatis agriculturae et silviculturae Mendelianae Brunensis*, 63(2): 539–552.
- ISO HELPLINE. 2014. *Integrated Management System Documentation / Manuals for Integrated Certification*. [Online]. Available at: http://www.iso-helpline.com/ims_iso_9000_iso_14000_ohsas_18000_document_manual.htm [Accessed: 2016, July 05].
- INTERNATIONAL ORGANIZATION FOR STANDARDIZATION. 2014. Social responsibility. ISO 26000. Available at: <http://www.iso.org/iso/iso26000>. [Accessed: 2016, July 05].
- JAMES, M. L. 2012. Sustainability and integrated reporting opportunities for small and midsize entities. *In Academy of Entrepreneurship*, 18(2): 17–28.
- JENÍČEK, V. 2013. Sustainable development – indicators. *Zemědělská ekonomika*, 59(2): 74–80.
- KASEM, E., TRENZ, O., HREBICEK, J. and FALDIK, O. 2015. Mathematical model for sustainability assessment of agriculture farms with biogas plants. In: *33rd International Conference on Mathematical Methods in Economics (MME)*. Cheb, Czech Republic. p. 343–348.
- KOCMANOVÁ, A., HŘEBÍČEK, J., DOČEKALOVÁ, M., HODINKA, M., HORNUNGOVÁ, J., CHVÁTALOVÁ, Z., KUBÁLEK, T., POPELKA, O., ŠIMBEROVÁ, I., TOPOLOVÁ, I. and TRENZ, O. 2013. *Corporate performance measuring* [in Czech: *Měření podnikové výkonnosti*]. Brno: Littera.
- KUBATA, K., TYRYCHTR, J., ULMAN, M. and VOSTROVSKÝ, V. 2014. Business Informatics and its Role in Agriculture in the Czech Republic. *AGRIS on-line Papers in Economics and Informatics*, 4: 59–66.

- NIKOLAOU, I. E. and TSALIS, T. A. 2013. Development of a sustainable balanced scorecard framework. *Ecological Indicators journal*, 34: 76–86.
- PIECHOCKI, M., FELDEN, C. and GRANING, A. 2007. Multidimensional XBRL reporting. In: *Proceedings of the Fifteenth European Conference on Information Systems*. ECIS 15. St. Gallen: University St. Gallen.
- SAFA. 2013. Sustainability Assessment of Food and Agriculture systems. *SAFA Guidelines version 2.0*. [Online]. Available at <http://www.fao.org/nr/sustainability/sustainability-assessments-safa/en/>. [Accessed: 2016, November 31].
- SAFA. 2014. SAFA (Sustainability Assessment of Food and Agriculture Systems) Tool. *User Manual Version 2.2.40*. [Online]. Available at <http://www.fao.org/3/a-i4113e.pdf>. [Accessed: 2016, October 07].
- SAMUEL, V. B., AGAMUTHU, P. and HASHIM, M. A. 2013. Indicators for assessment of sustainable production: A case study of the petrochemical industry in Malaysia. *Ecological Indicators journal*, 24: 392–402.
- SCHADER, C., GRENZ, J., MEIER, M. S. and STOLZE, M. 2014. Scope and precision of sustainability assessment approaches to food systems. *Ecology and Society journal*, 19(3): 42.
- SCHINDLER, J., GRAEF, F. and KONIG, H. J. 2015. Methods to assess farming sustainability in developing countries. A review. *Agronomy for Sustainable Development*, 35(3): 1043–1057.
- SHAHI, A. M., ISSAC, B. and MODAPOTHALA, J. R. 2012. Intelligent Corporate Sustainability report scoring solution using machine learning approach to text categorization. In: *Sustainable Utilization and Development in Engineering and Technology (STUDENT) conference*. p. 227–232.
- STASTNY, J. and SKORPIL, V. 2007. Analysis of Algorithms for Radial Basis Function Neural Network. In: BESTAK, R., SIMAK, B. and KOZLOWSKA, E. (Eds). *Personal Wireless Communications*. IFIP – The International Federation for Information Processing, vol 245. Boston, MA: Springer.
- TOKOS, H., PINTARIČ, Z. N. and KRAJNC, D. 2012. An integrated sustainability performance assessment and benchmarking of breweries. *Clean Technologies and Environmental Policy*, 14(2): 173–193.
- XBRL. 2012. *An Introduction to XBRL*. [Online]. Available at: <http://www.xbrl.org> [Accessed: 2016, November 20].
- YEGBEMEY, R. N., YABI, J. A., DOSSA, C. S. G. and BAUER, S. 2014. Novel participatory indicators of sustainability reveal weaknesses of maize cropping in Benin. *Agronomy for Sustainable Development*, 34: 909–920.
- WANG, Y. M. and CHIN, K. S. 2010. Some alternative models for DEA cross-efficiency evaluation. *Int. J. Production Economics*, 128(1): 332–338.

Contact information

Ing. Edward Kassem: edward.kassem@gmail.com
doc. Ing. Oldřich Trenz, Ph.D.: oldrich.trenz@mendelu.cz
prof. RNDr. Jiří Hřebíček, CSc.: jiri.hrebicek@mendelu.cz
Ing. Oldřich Faldík: oldrich.faldik@mendelu.cz